

SA800/801

Illustrated Parts Catalog

© Copyright 1977 Shugart Associates

TABLE OF CONTENTS

Description	1
Basic Assembly (Figure 1)	2
Stepper/Carriage (Figure 2)	6
Cartridge Guide	8
Front Plate (Figure 4)	10
Numerical Index	12

DESCRIPTION

General

The Illustrated Parts Catalog is arranged so that the figures will always precede the parts listings and when possible be on the opposite page.

The first number in the list will always refer to the figure and the second number to the reference number of the part within the figure.

When an assembly is referred to within a figure and a further breakdown is shown on another figure then the reference figure will be called out.

Indented Level

The parts list is indented to show the levels of assembly within a figure. The major assembly will always be level 1, all parts or assemblies that attach to that assembly will be level 2 and assemblies within level 2 will have their attaching parts level 3 and so on.

Quantity Per Assembly

The quantity listed is the quantity used on the major assembly. Major Assemblies will never have a quantity listed.

Numerical Index

The numerical index lists all parts in part number sequence and is cross referenced to the figure and reference number.

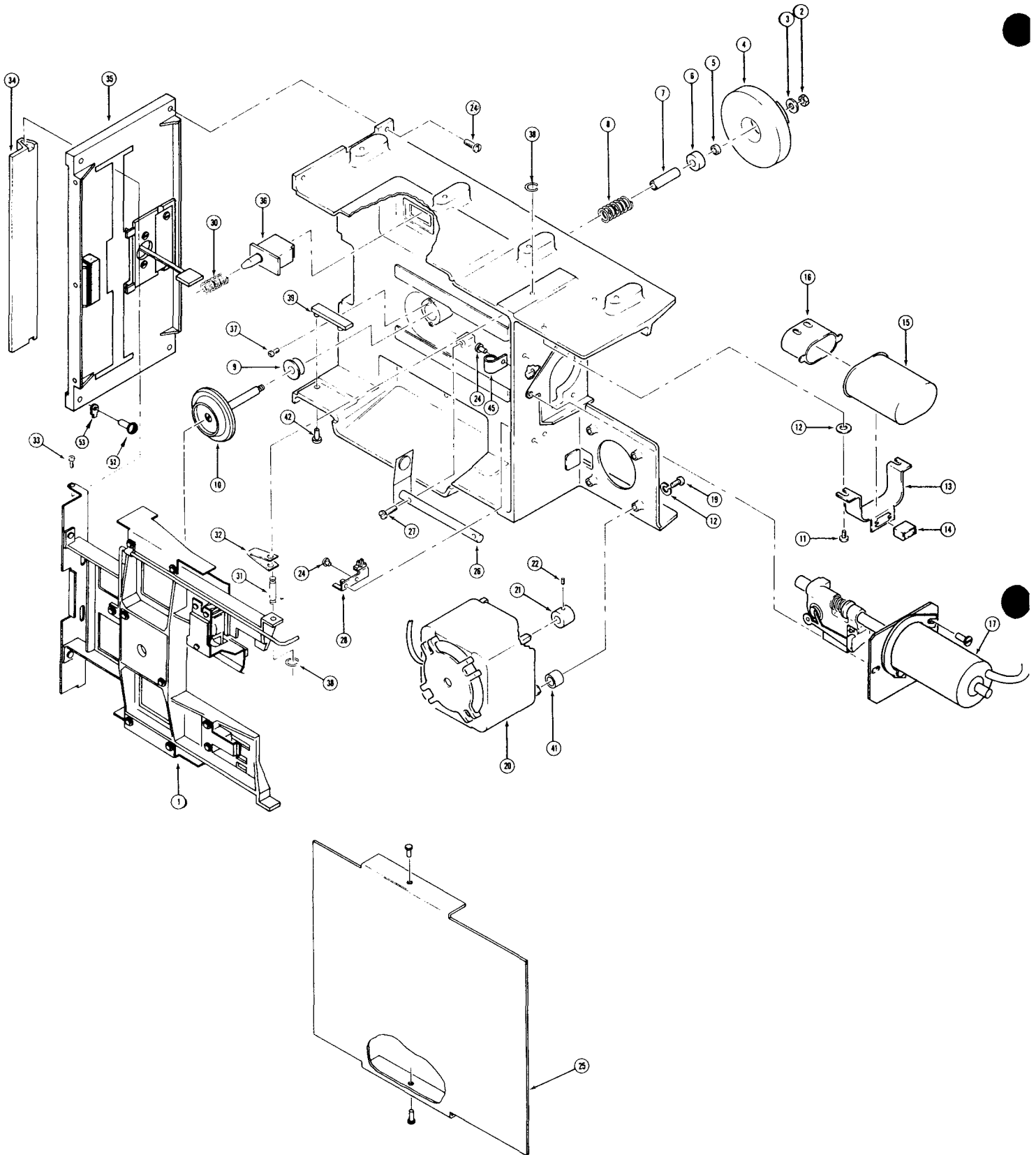

Figure 1 (1 of 2)

FIGURE & REF. NUMBER	PART NUMBER	DESCRIPTION				QTY PER ASM.
		1	2	3	4	
1		DRIVE ASSEMBLY SA800/801				
-1	50550	. CARTRIDGE GUIDE ASSEMBLY (SEE FIG. 3)				1
-2	10025	. NUT, 8-32				1
-3	12509	. WASHER, SPRING				2
-4	50016	. PULLEY ASSEMBLY, SPINDLE				1
-5	50019	. SPACER, SPINDLE-SHORT				1
-6	10800	. BEARING, SPINDLE				1
-7	50018	. SPACER, SPINDLE---LONG				1
-8	50166	. SPRING, SPINDLE				1
-9	10801	. FLANGED BEARING, SPINDLE				1
-10	50561	. HUB ASSEMBLY, SPINDLE				1
-11	12015	. SCREW, 8-32x.312				5
-12	12500	. WASHER; LOCK # 8				2
-13	50098	. BRACKET				1
-14	10150	. HOUSING, 3 PIN CONNECTOR				1
-15	10095	. CAPACITOR, 110 V 50/60 HZ (BODINE MTR ONLY)				1
	15004	. CAPACITOR, 220 V 50/60 HZ OR 110V ORIENTAL MTR				
-16	10148	. RUBBER BOOT				1
-17		. STEPPER/CARRIAGE ASSEMBLY (SEE FIG. 2)				1
-19	12028	. SCREW, 8-32x.750				4
-20	50443	. MOTOR, 110 VOLT 50/60 HZ KIT				1
	50301	. MOTOR, 208/230/220 VOLT 50/60 HZ				
-21	50358	. PULLEY, 60 HZ				1
	50357	. PULLEY, 50 HZ				
-22	11904	. SCREW, SET 6-32x.125				1
-23	10378	. CABLE CLAMP, 1/8 INCH				1
-24	12013	. SCREW 6-32x.312 (12014 FOR ZINC FACEPLATE)				11
	10191	. SCREW 6-32x.438 -800R				2
-25	50440	. DUST COVER KIT (OPTIONAL)				1
	12023	. . SCREW, THD. FORM, PAN HD.				2
	50009	. . COVER				1
-26	50522	. SPRING/GUIDE ASM				1
-27	12012	. SCREW, 4-40x.375				2
-28	50121	. DETECTOR ASSEMBLY, TRACK 0				1
-30	50582	. SPRING ASSEMBLY, DOOR OPEN (STANDARD)				1
	50583	. SPRING ASSEMBLY, DOOR OPEN (HORZ. MNT, PCB DOWN)				
-31	50167	. PIVOT TOP				1
	50670	. PIVOT TOP (STANDARD) (800R)				
-32	50168	. SPRING, BIAS				1
-33	11905	. SCREW, B.V.				2
-34	50142	. HANDLE				1
-35		. FRONT PLATE ASSEMBLY (SEE FIG. 4)				1
-36	17200	. SWITCH, DOOR OPEN				1
-37	12011	. SCREW, 4-40x.250				2
-38	11305	. CLIP				2
-39	50559	. DEFLECTOR				2
-41	50602	. SPACER				4
-42	12032	. SCREW, # 8x.50 LG TAPPING				2

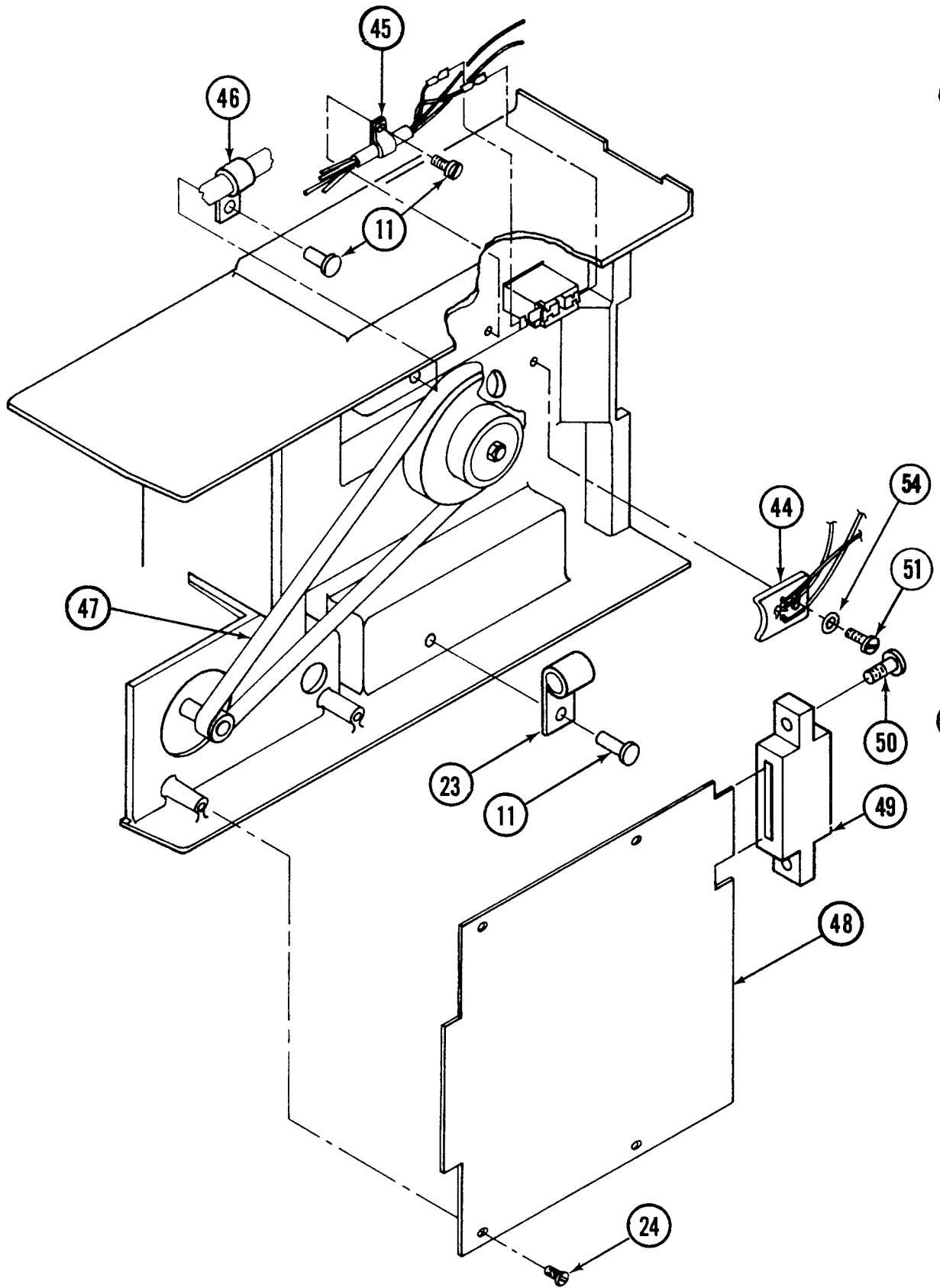

Figure 1 (2 of 2)

FIGURE & REF. NUMBER	PART NUMBER	DESCRIPTION				QTY PER ASM.
		1	2	3	4	
-44	50128	.	PHOTRANSISTOR AND CABLE ASSEMBLY			1
-45	10375	.	CABLE CLAMP, 3/16"			2
-46	10264	.	CABLE CLAMP, 3/8"			1
-47	50356	.	BELT (60 HZ)			1
	50355	.	BELT (50 HZ)			1
-48	25102	.	PCB (SA 800, -5V, NO DATA SEP)			1
	25103	.	PCB (SA 800, -12/-15V, NO DATA SEP)			
	25104	.	PCB (SA 800, -5V, WITH DATA SEP)			
	25105	.	PCB (SA 800, -12/-15V, WITH DATA SEP)			
	25106	.	PCB (SA 801, -5V)			
	25107	.	PCB (SA 801, -12/-15V)			
-49	10140	.	BLOCK, PCB CONN			1
-50	10174	.	.SCREW, 4-40			2
-51	12036	.	SCREW, 8-32x.375			1
-52	10187	.	SCREW, 6-32x.250 -800R			2
-53	50669	.	CLIP, FACE PLATE MOUNT-800R			2
-54	10014	.	WASHER			1

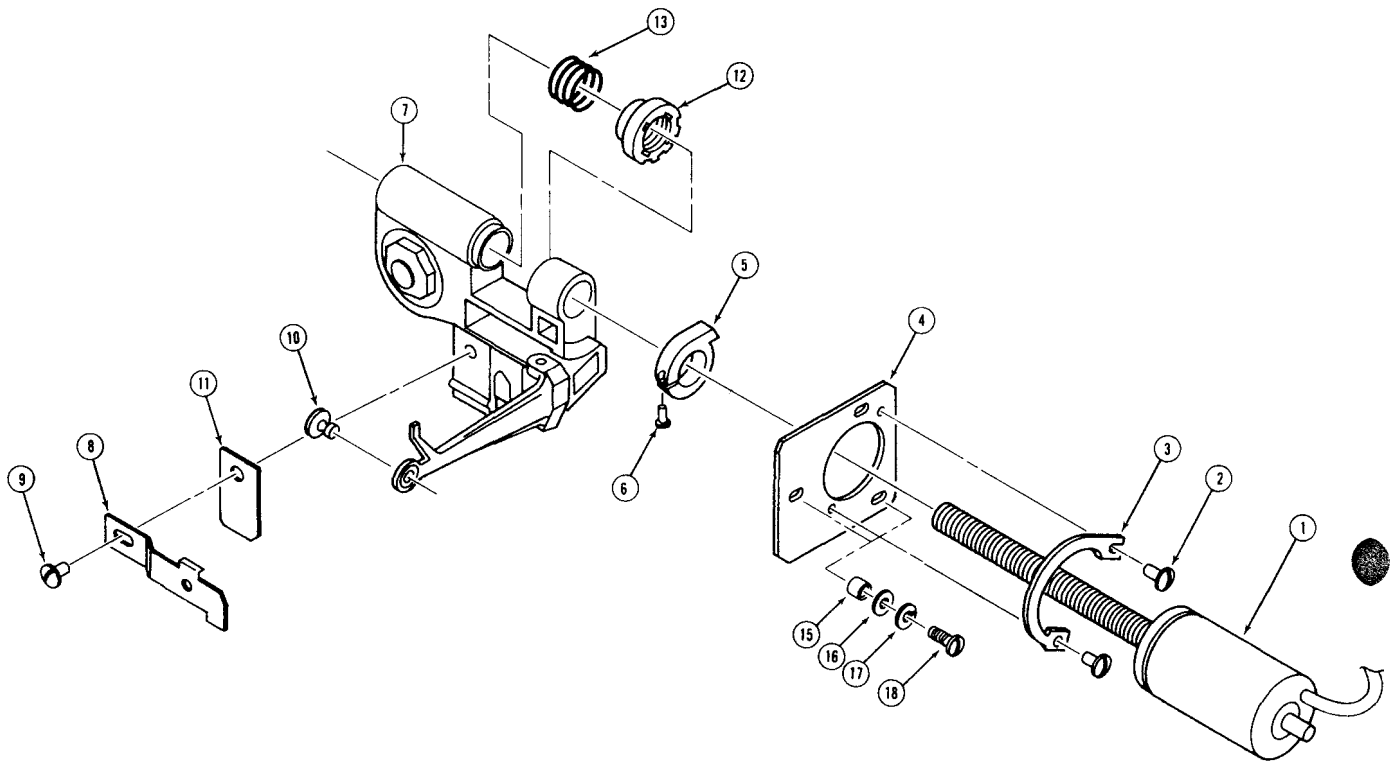

Figure 2

FIGURE & REF. NUMBER	PART NUMBER	DESCRIPTION				QTY PER ASM.
		1	2	3	4	
2-		STEPPER/CARRIAGE ASSEMBLY				
-1	50130	.				1
-2	12016	.				2
-3	50584	.				1
-4	50112-4	.				1
-5	50245	.				1
-6	11903	.				1
-7	50562	.				1
-8	50529	.	.			1
-9	11910	.	.			1
-10	50542	.	.			1
-11	50362	.	.			1
-12	50087	.	.			1
-13	50088	.	.			1
-14	10012	.	.			1
-15	50707	.				1
-16	10013	.				3
-17	12510	.				3
-18	12027	.				3

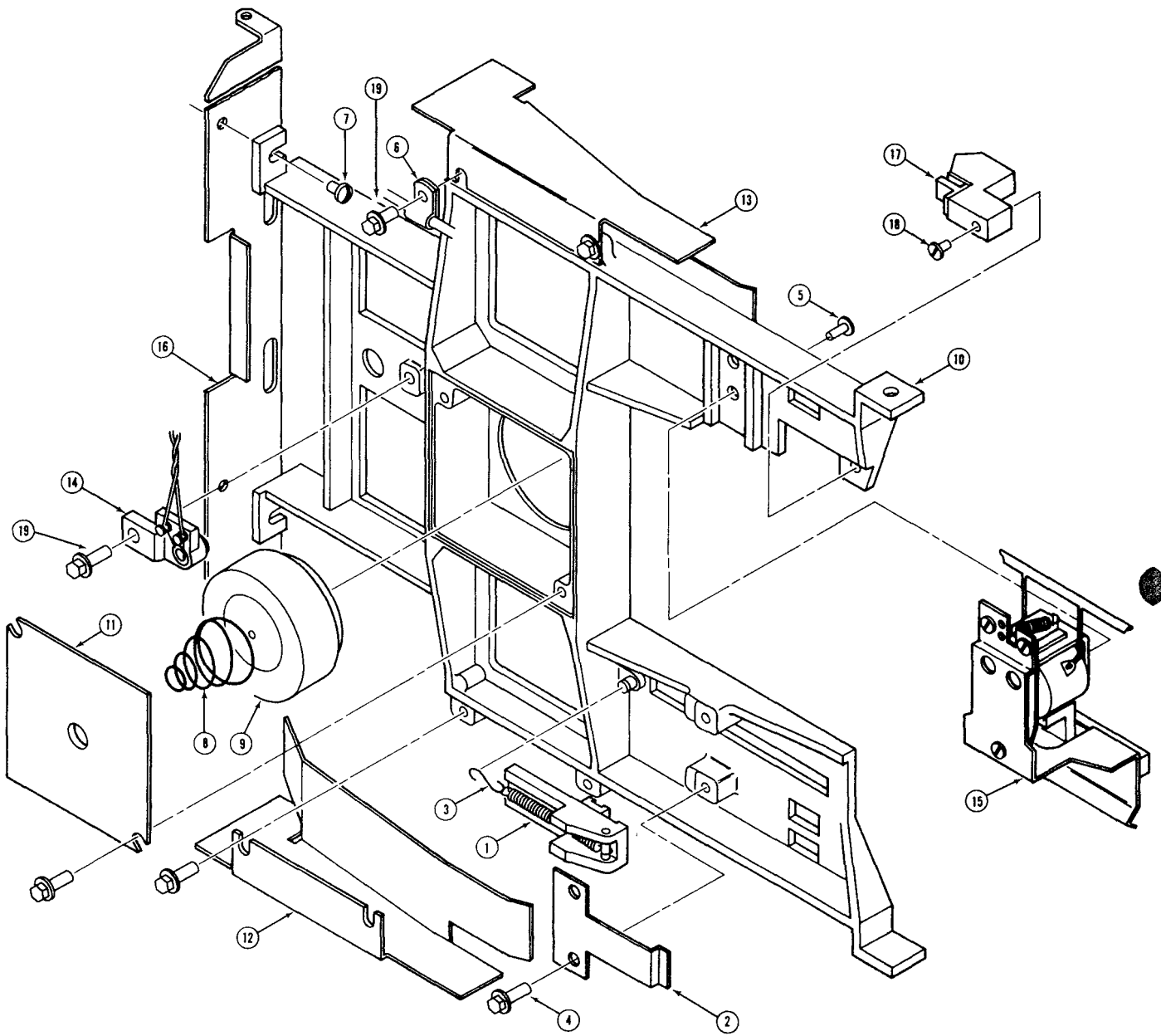

Figure 3

FIGURE & REF. NUMBER	PART NUMBER	DESCRIPTION				QTY PER ASM.
		1	2	3	4	
3-	50550	CARTRIDGE GUIDE ASSEMBLY				
1	50609	.				1
2	50555	.				1
3	50556	.				1
4	12015	.				7
5	12013	.				1
6	10378	.				1
7	10187	.				2
8	50031	.				1
9	50254	.				1
10	50544	.				1
11	50546	.				1
12	50547	.				1
13	50548	.				1
14	50557	.				1
15	50558	.				1
16	50579	.				1
17	50313	.				1
18	12026	.				1
19	12016	.				2

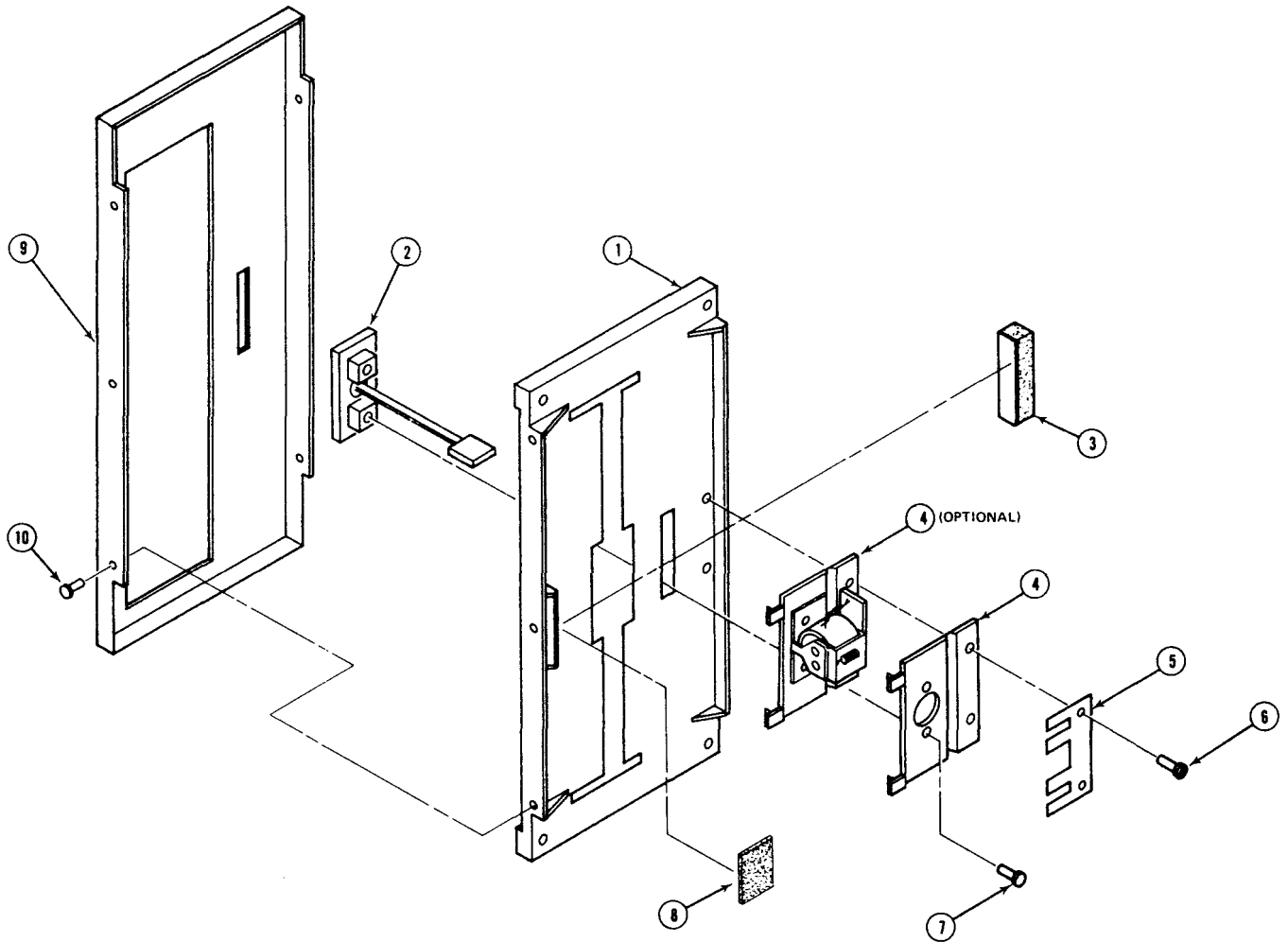

Figure 4

FIGURE & REF. NUMBER	PART NUMBER	DESCRIPTION				QTY PER ASM.
		1	2	3	4	
4-	50733	FRONT PLATE ASSEMBLY (WITH LITE)				
	50731	FRONT PLATE ASSEMBLY (WITHOUT LITE)				
	50735	FRONT PLATE ASM KIT (WITH DOOR LOCK)				
	50679	FRONT PLATE ASM-800R (WITHOUT LITE)				
	50680	FRONT PLATE ASM-800R (WITH LITE)				
	50724	FRONT PLATE ASM-800R (WITH DOOR LOCK)				
-1	50729	.	FRONT PLATE			1
	50667	.	FRONT PLATE-800R			1
-2	50727	.	PUSH BUTTON (WITH LITE)			1
	50726	.	PUSH BUTTON, DOOR LOCK OPTION			
-3	50728	.	PUSH BUTTON (WITHOUT LITE)			1
	50183	.	BUMPER			1
-4	50156	.	LATCH			1
	50690	.	LATCH ASM, DOOR LOCK OPTION			
-5	50691	.	SPRING PLATE			1
-6	12013	.	SCREW 6-32x.312			2
-7	12035	.	SCREW 4-40x.250			2
-8	50580	.	SNATCH			1
-9	50257	COVER, FRONT 5-1/4 x 11 WHITE				1
	50258	COVER, FRONT 5-1/4 x 11 TAN				1
	50260	COVER, FRONT 5-1/4 x 10 WHITE				1
	50261	COVER, FRONT 5-1/4 x 10 TAN				1
	50263	COVER, FRONT 4-5/8 x 10-1/2 WHITE				1
	50264	COVER, FRONT 4-5/8 x 10-1/2 TAN				1
-10	50675	COVER, FRONT-800R TAN				1
	10261	SCREW, FL. HD. 4-40x.250				5

PART NUMBER	FIG. REF.
10012	2-14
10013	2-16
10014	1-54
10025	1-2
10095	1-15
10140	1-49
10148	1-16
10150	1-14
10174	1-50
10187	3-7
	1-52
10191	1-24
10261	4-10
10264	1-46
10375	1-45
10378	1-23
	3-6
10800	1-6
10801	1-9
11305	1-38
11903	2-6
11904	1-22
11905	1-33
11910	2-9
12011	1-37
12012	1-27
12013	1-24
	3-5
	4-6
12015	1-11
	3-4
12016	
	2-2
	3-19
12023	1-25
12026	3-18
12027	2-18
12028	1-19
12032	1-42
12036	1-51
12500	1-12
12509	1-3
12510	2-17
15004	1-15
17200	1-36
25102	1-48
25103	1-48
25104	1-48
25105	1-48
25106	1-48
25107	1-48
50009	1-25
50016	1-4
50018	1-7
50019	1-5
50031	3-8

PART NUMBER	FIG. REF.
50087	2-12
50088	2-13
50098	1-18
50112-4	2-4
50121	1-28
50128	1-44
50130	2-1
50142	1-34
50156	4-4
50166	1-8
50167	1-31
50168	1-32
50183	4-3
50245	2-5
50254	3-9
50257	4-9
50258	4-9
50260	4-9
50261	4-9
50263	4-9
50264	4-9
50301	1-20
50313	3-17
50355	1-47
50356	1-47
50357	1-21
50358	1-21
50362	2-11
50440	1-25
50443	1-20
50522	1-26
50529	2-8
50542	2-10
50544	3-10
50546	3-11
50547	3-12
50548	3-13
50550	1-1
	3
50555	3-2
50556	3-3
50557	3-14
50558	3-15
50559	1-39
50561	1-10
50562	2-7
50579	3-16
50580	4-8
50582	1-30
50583	1-30
50584	2-3
50602	1-41
50609	3-1
50667	4-1
50669	1-53
50670	1-31

PART NUMBER	FIG. REF.
50675	4-9
50679	4
50680	4
50690	4-4
50691	4-5
50707	2-15
50724	4
50726	4-2
50727	4-2
50728	4-2
50729	4-1
50731	4
50733	4
50735	4

SA800/801 Diskette Storage Drive

Maintenance Manual

TABLE OF CONTENTS

Section		Page
1	Maintenance Features	1
2	Diagnostic Techniques	3
3	Preventive Maintenance	5
4	Removals Adjustments	7
5	Physical Locations	17
6	SA809 Exerciser Connections	21
7	SA800/801 PCB Component Locations	22
8	SA800/801 Logic Manual	23
9	SA800/801 Schematic Diagrams	31

1.0 MAINTENANCE FEATURES

1.1 Alignment Diskette

The SA120 Alignment Diskette is used for alignment of the SA800/801. The following adjustments can be made using the SA120.

1. R/W Head radial alignment using track 38.
2. R/W Head azimuth alignment using track 76.
3. Index Photo-Detector Adjustment using tracks 01 and 76.
4. Track 00 is recorded with standard IBM 3740 format.
5. TK 75 has 1f + 2f signal for load pad adjustment.

Caution should be exercised in using the SA120 Alignment Diskette. Tracks 00, 01, 36, 37, 38, 39, 40, 75, and 76 should not be written on. To do so will destroy pre-recorded tracks.

1.2 SA809 Exerciser

The SA809 Exerciser is built on a PCB whose dimensions are 8" x 8". The Exerciser PCB can be used in a stand alone mode or it can be built into a test station or used in a tester for field service.

The Exerciser is designed to enable the user to make all adjustments and check outs required on the SA800/801 drives, when used with the SA120 alignment diskette.

The exerciser has no intelligent data handling capabilities but can write both 1f and 2f frequencies. The exerciser can enable read in the drive to allow checking of read back signals.

Refer to Section 6 for illustration.

1.3 Special Tools

The following special tools are available for performing maintenance on the SA800/801.

Description	Part Number
Alignment Diskette	SA120-1
Cartridge Guide Adj. Tool	50377-1
Head Penetration Gauge	50380-0
Load Bail Gauge	50391-0
Exerciser	50619-0
Spanner Wrench	50752-0

2.0 DIAGNOSTIC TECHNIQUES

2.1 Introduction

Incorrect operating procedures, faulty programming, damaged diskettes, and "soft errors" created by airborne contaminants, random electrical noise, and other external causes can produce errors falsely attributed to drive failure or misadjustment.

Unless visual inspection of the drive discloses an obvious misalignment or broken part, attempt to repeat the fault with the original diskette, then attempt to duplicate fault on second diskette.

2.2 "Soft Error" Detection and Correction

Soft errors are usually caused by:

1. Airborne contaminants that pass between the read/write head and the disk. Usually these contaminants can be removed by the cartridge self-cleaning wiper.
2. Random electrical noise that usually lasts for a few μ sec.
3. Small defects in the written data and/or track not detected during the write operation that may cause a soft error during a read.
4. Worn or defective load pad.

The following procedures are recommended to recover from the above mentioned soft errors:

1. Reread the track ten (10) times or until such time as the data is recovered.
2. If data is not recovered after using step 1, access the head to the adjacent track in the same direction previously moved, then return to the desired track.
3. Repeat step 1.
4. If data is not recovered, the error is not recoverable.

2.3 Write Error

If an error occurs during a write operation, it will be detected on the next revolution by doing a read operation, commonly called a "write check." To correct the error, another write and write check operation must be done. If the write operation is not successful after ten (10) attempts have been made, a read operation should be attempted on another track to determine if the media or the drive is failing. If the error still persists the diskette

should be replaced and the above procedure repeated. If the failure still exists, consider the drive defective. If the failure disappears, consider the original diskette defective and discard it.

2.4 Read Error

Most errors that occur will be "soft" errors. In these cases, performing an error recovery procedure will recover the data.

2.5 Seek Error

1. Stepper malfunction.
2. Improper carriage torque.

To recover from a seek error recalibrate to track 00 and perform another seek to the original track.

2.6 Test Points—800/801

TP	1	Read Data Signal
	2	Read Data Signal
	3	Read Data (Differentiated)
	4	Read Data (Differentiated)
	5	Signal Ground
	6	Signal Ground
	7	Signal Ground
	10	- Index
	11	+ Head Load
	12	- Index and 801 Sector Pulses
	16	+ Read Data
	21	- Data Separator Time + 1
	24	- Data Separator Time + 2
	25	+ Write Protect
	26	+ Detect Track 00.
	27	+ Gated Step Pulses

2.7 Test Point Locations

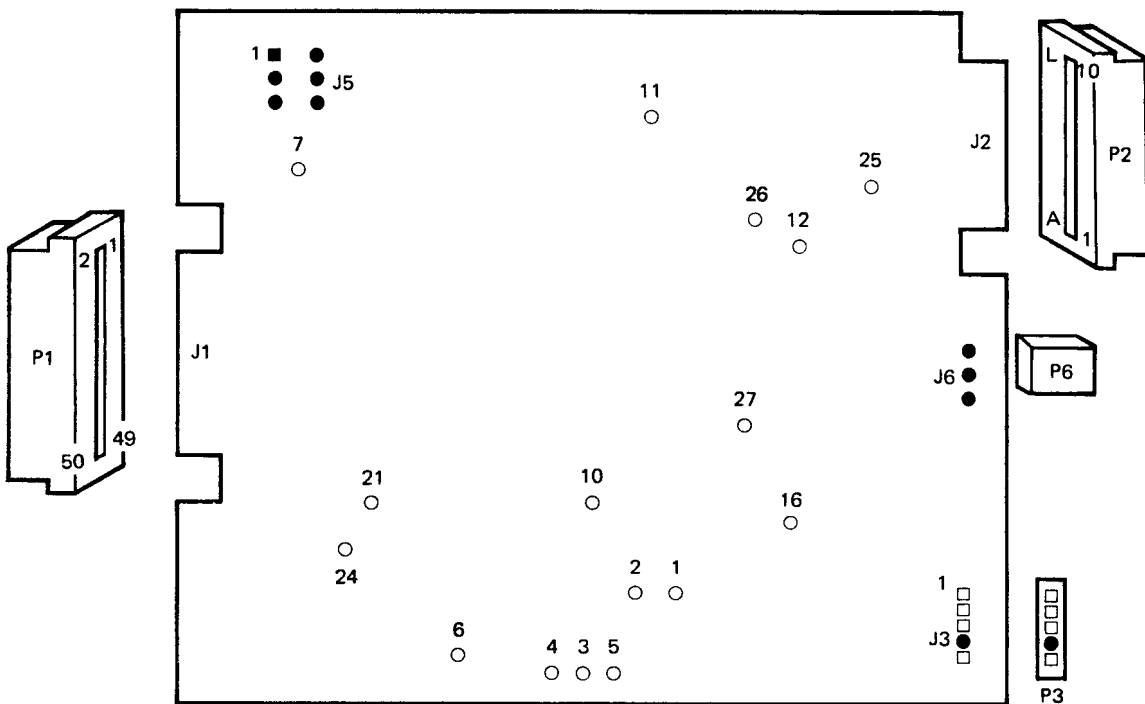

3.0 PREVENTIVE MAINTENANCE

3.1 Introduction

The prime objective of any preventive maintenance activity is to provide maximum machine availability to the user. Every preventive maintenance operation should assist in realizing this objective. Unless a preventive maintenance operation cuts machine downtime, it is unnecessary.

Visual inspection is the first step in every scheduled maintenance operation. Always look for corrosion, dirt, wear, binds, and loose connections. Noticing these items during PM may save downtime later.

Remember, do not do more than recommended preventive maintenance on equipment that is operating satisfactorily.

3.2 Preventive Maintenance Procedures

Details of preventive maintenance operations are listed in Figure 1. During normal preventive maintenance, perform only those operations listed on the chart for that preventive maintenance period. Details on adjustments and service checks can be found in the maintenance manual. Observe all safety procedures.

3.3 Cleanliness

Cleanliness cannot be overemphasized in maintaining the SA800/801. Do not lubricate the SA800/801; oil will allow dust and dirt to accumulate. The read/write head should be cleaned only when signs of oxide build up are present.

UNIT	FREQ MONTHS	CLEAN	OBSERVE
Read/Write Head	12	Clean Read/Write Head ONLY IF NECESSARY	Oxide build up
R/W Head Load Button	12*	Replace	
Stepper Motor and Lead Screw	12	Clean off all oil, dust, and dirt	Inspect for nicks and burrs
Belt	12		Frayed or weakened areas
Base	12	Clean base	Inspect for loose screws, connectors, and switches
Read/Write Head	12		Check for proper alignment

*Assumes normal usage

Figure 1 PM Procedures

4.0 REMOVALS, ADJUSTMENTS

For parts location, see Section 5.

4.1 Motor Drive

4.1.1 Drive Motor Assembly: Removal and Installation

- a. Extract 3 contacts to disconnect motor from AC connector.
- b. Loosen two screws holding capacitor clamp to the base. Remove rubber boot and disconnect motor leads from capacitor.
- c. Remove connectors from PCB and remove PCB.
- d. Remove belt from drive pulley.
- e. Remove 4 screws holding the motor to the base casting and remove motor.
- f. Reverse the procedure for installation.

Note: Insure ground lead is installed between capacitor clamp and base.

4.1.2 Motor Drive Pulley

- a. Loosen set screw and remove pulley.
- b. Reverse procedure for installation.

Note: When installing a new pulley, the drive pulley must be aligned with the spindle pulley so that the belt tracks correctly.

4.2 Side Cover Removal

- a. Retract screw from upper casting wall sufficiently to allow the side cover to be rocked out.
- b. Lift cover off screw in lower casting wall.

4.3 Cartridge Guide Access

- a. Remove side cover (Section 4.2).
- b. Position head to approximate center of head load bail (to prevent load arm damage).
- c. Loosen 2 screws holding cartridge guide to door latch plate.
- d. Swing cartridge guide out.
- e. When the guide is swung in, it must be adjusted as per Section 4.9.2.

4.4 Sector/Index LED Assembly: Removal and Installation

- Remove side cover (Section 4.2).
- Disconnect the wires to the LED terminals (solder joints).
- Remove the screw holding the LED assembly to the cartridge guide.
- Reverse the procedure for installation.
- Check index timing and readjust if necessary.

4.5 Write Protect Detector: Removal and Installation

- Remove connectors from PCB and remove PCB.
- Extract wires from P2 connector, pins L3, L4, R5 (E), and R8 (S).
- Remove cable clamps.
- Remove side cover (Section 4.2).
- Remove screw holding the detector bracket and remove assembly.
- Reverse procedure for reinstalling. Connect the wires to P2 by the following: Red to '3' (L3), Grey to '4' (L4), Black to 'E' (R5) and White to 'J' (R8).

4.5.1 Write Protect Detector Adjustment

- Insert SA101 diskette into drive. Write protect hole must be open.
- Set oscilloscope to AUTO sweep, 2V/div. and monitor TP25.
- Loosen screw on detector assembly and adjust until maximum amplitude is achieved. Tighten screw.

4.6 Head Load Actuator

4.6.1 Head Load Actuator: Removal and Installation

- Remove side cover (Section 4.2).
- Disconnect the wires to the actuator terminals (solder joints).
- Swing out the cartridge to guide assembly (Section 4.3).

- Remove screw holding the actuator to the cartridge guide.

CAUTION: Restrain the head load arm to prevent its impact with the head.

- Reverse the procedure for installation.

4.6.2 Head Load Actuator Adjustment

- Remove side cover.
- Energize Head Load Coil.
- Place Head Load Actuator adjustment tool, P/N 50391, on platen.
- Adjust down stop so that the top of Head Load Bail is flush with top of tool within $\pm .005$ " at track 76. Reference Figure 3.
- Step carriage to track 38.
- De-energize Head Load Coil.
- Place adjustment tool onto R/W Head and place load button in cup of tool.
- Adjust up stop on actuator so that bail just touches Head Load Arm or has $.005$ " clearance or lifts Load Arm $.005$ ". Reference Figure 2.
- Energize Head Load Coil and step carriage between track 00 and 76. Insure that there is a clearance of a minimum of $.010$ " between Head Load Bail and Head Load Arm.
- Replace side cover.

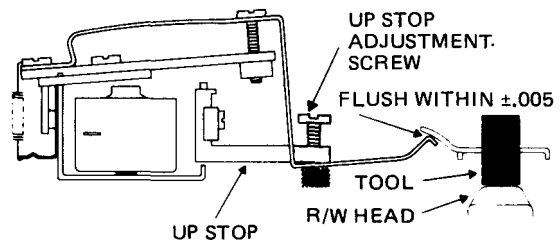

FIGURE 2 HEAD LOAD ACTUATOR UPSTOP ADJUSTMENT

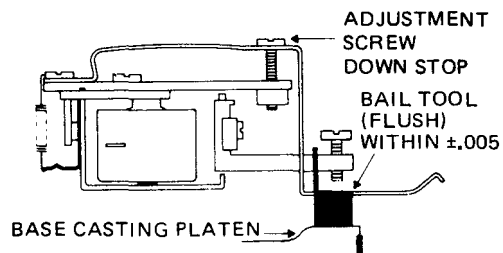

FIGURE 3 HEAD LOAD ACTUATOR DOWN STOP ADJUSTMENT

4.6.3 Head Load Actuator Timing

- a. Insert Alignment Diskette (SA120).
- b. Step carriage to track 00.
- c. Sync oscilloscope on TP11 (+ Head Load). Set time base to 10MSEC/division.
- d. Connect one probe to TP1 and the other to TP2. Ground probes to the PCB. Set the inputs to add and invert one input
- e. Energize the Head Load solenoid and observe the read signal on the oscilloscope. The signal must be at 50% of full amplitude by 35Msec. Reference Figure 4.
- f. If this is not met, continue on with the procedure.
- g. Check adjustments outlined in paragraph 4.6.2.
- h. If item 'g' is ok, adjust down stop screw (Figure 6) clockwise until timing is met.

Note: Not to exceed $\frac{1}{4}$ turn.

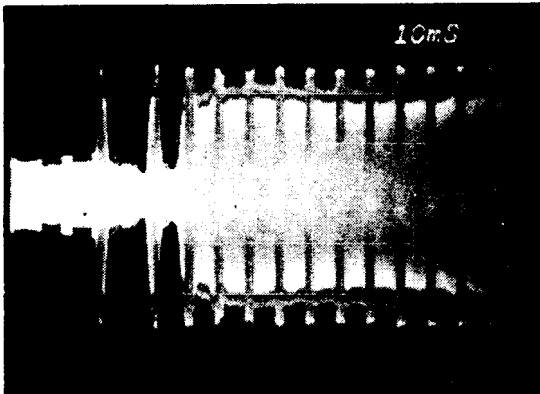

FIGURE 4 HEAD LOAD ACTUATOR TIMING

4.7 Index/Sector Photo Transistor Assembly

4.7.1 Index/Sector Photo Transistor Assembly: Removal and Installation

- a. Disconnect P2 connector from PCB.
- b. Remove wires from Door Closed switch and extract wires from P2 connector pin 9 (L9) Black, H (R7) Brown, 6 (L6) Red and B (R2) Orange.
- c. Remove cable clamp holding wires from detector.

- d. Remove screw holding detector to the base plate and remove assembly.
- e. To install reverse procedure.

4.7.2 Index/Sector Photo Transistor Potentiometer Adjustment

- a. Insert Alignment Diskette (SA120).
- b. Using oscilloscope monitor TP-12 (- Index), sync internal negative, DC coupled, set vertical scale to 2 V/cm.
- c. Adjust the potentiometer on the Sector/Index Phototransistor to obtain a pulse of 1.7 msec. $\pm .5$ msec. duration.
- d. Continue adjustment in Section 4.7.3.

4.7.3 Index/Sector Adjustment

- a. Insert Alignment Diskette (SA120).
- b. Step carriage to track 01.
- c. Sync oscilloscope, external negative, on TP 12 (- Index). Set time base to 50 μ sec/division.
- d. Connect one probe to TP 1 and the other to TP 2. Ground probes to the PCB. Set the inputs to AC, Add and invert one channel. Set vertical deflection to 500 MV/division.
- e. Observe the timing between the start of the sweep and the first data pulse. This should be $200 \pm 100 \mu$ sec. If the timing is not within tolerance, continue on with the adjustment. Reference Figure 5.

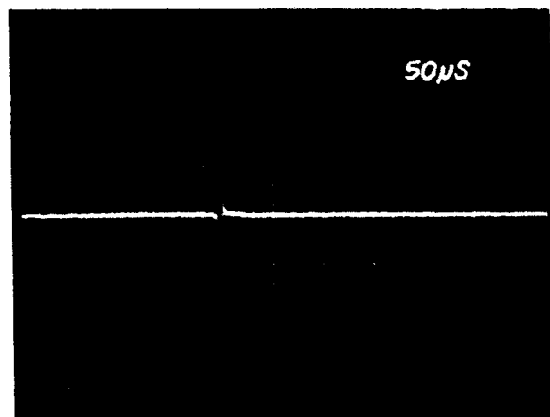

FIGURE 5 INDEX TIMING

- f. Loosen the holding screw in the Index Transducer until the transducer is just able to be moved.
- g. Observing the timing, adjust the transducer until the timing is $200 \pm 100 \mu\text{sec}$. Insure that the transducer assembly is against the registration surface on the base casting.
- h. Tighten the holding screw.
- i. Recheck the timing.
- j. Seek to track 76 and reverify that the timing is $200 \pm 100 \mu\text{sec}$.

4.8 Spindle Assembly

- a. Remove side cover (Section 4.2).
- b. Swing out cartridge guide (Section 4.3).
- c. Remove the nut and washer or 2 spring washers holding the spindle pulley. On late level drives, Spanner Wrench 50752 may be used to hold spindle.
CAUTION: The pre-loaded rear bearing may fly out when spindle pulley is removed.
- d. Withdraw spindle hub from opposite side of baseplate.
- e. Reverse the procedure for installation.
- f. Tighten nut to 20 in./lbs. If spring washers are used, insure they are compressed. Add a drop of LOCTITE® #290 to threads.

4.8.1 Clamp Hub Removal

- a. Remove hub clamp plate. Reference Figure 6.
- b. Remove clamp hub and spring.
- c. To install, reverse the procedure. No adjustment necessary.

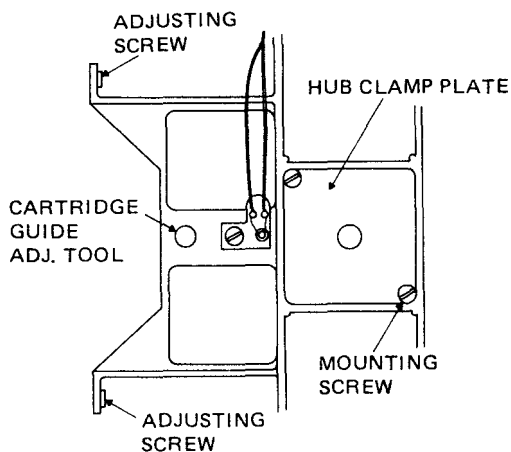

FIGURE 6 CARTRIDGE GUIDE ADJUSTMENT

4.9.1 Cartridge Guide Removal

- a. Perform steps 4.3 through 4.6.1.
- b. Remove C-clip from pivot shaft. Reference Figure 7.
- c. Remove pivot shaft.
- d. Tilt the cartridge guide slightly, and remove it from the upper pivot.
- e. To install the cartridge guide, reverse the procedure.

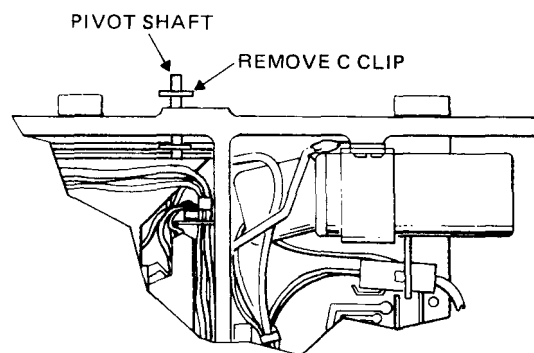

FIGURE 7 CARTRIDGE GUIDE REMOVAL

4.9.2 Cartridge Guide Adjustment

- a. Insert the shoulder screw (tool P/N 50377-1) through the adjustment hole in the cartridge guide and screw completely into the base casting (hand tight). Reference Figure 6.
- b. Move the handle into the latched position and hold it lightly against the latch.
- c. Tighten two screws holding the cartridge guide to the latch plate.
- d. Remove the tool and check to determine the flange on the clamp hub clears the cartridge guide when the spindle is rotating. If the clamp hub rubs on the cartridge guide, repeat the adjustment procedure.
- e. Check index alignment per Section 4.7.3.
- f. Insert diskette, close and open door, then check for proper operation.

4.10 Front Plate Assembly: Removal

- a. Remove side cover (Section 3.4.2).
- b. Swing out the cartridge guide assembly (Section 4.3).

- c. Remove 4 screws holding the front plate assembly to the base casting.
- d. To install, reverse the procedure.
- e. Check Index adjustment Section 4.7.3.

4.11 Head Amplitude Check

These checks are only valid when writing and reading back as described below. If this amplitude is below the minimum specified, the load pad should be replaced and the head should be cleaned if necessary before re-writing and re-checking. Insure the diskette used for this check is not "worn" or otherwise shows evidence of damage on either the load pad or head side.

- a. Install good media.
- b. Select the drive and step to TK 76.
- c. Sync the oscilloscope on TP-12 (- Index) connect one probe on TP-2 and one on TP-1, on the drive PCB. Ground the probes to the PCB add and invert one input. Set volts per division to 50mv and time base to 20 M sec. per division.
- d. Write the entire track with 2F signal (all one's).
- e. The average minimum read back amplitude, peak to peak, should be 110 millivolts.

If the output is below minimum and a new load pad and different media is tried and the output is still low, it will be necessary to install a new head and carriage assembly.

4.11.1 Stepper/Carriage Assembly; Removal and Installation

- a. Remove cable clamp holding R/W head cable on PCB side of drive.
- b. Remove side cover (Section 4.2).
- c. Extract stepper cable contacts from P2 connector. Black 10 (L10), Red 2 (L2), Brown 5 (L5), and Orange 8 (8).

Note: This step is only necessary if the stepper motor is to be replaced.

- d. Loosen (2) screws and swing clamp down to allow withdrawal of motor.

CAUTION: DO NOT LOOSEN THREE SCREWS COATED WITH GLYPTOL.

- e. Remove the grommet on the cable that is inserted into a slot on the Track 00 Detector bracket.
- f. Turn stepper shaft until the carriage runs off the end of the lead screw.
- g. To install stepper/carriage assembly, reverse procedure. Note steps "h" and "i".
- h. If installing a new carriage, set the pre-load nut in the #2 notch. Reference Figure 8.
- i. When threading lead screw into carriage assembly, press the pre-load nut slightly against spring in order to start thread. After threading, insure there is a gap between pre-load nut and rear of carriage.

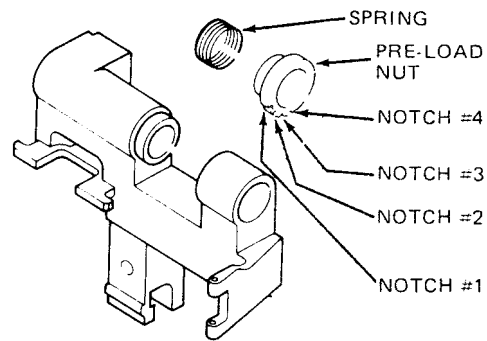

FIGURE 8 CARRIAGE ASSEMBLY

4.11.2 Carriage Assembly Readjustment After Replacement

- a. Loosen Track 00 stop collar and manually move the carriage towards the stepper by rotating the lead screw until the carriage load arm tab is near the edge of the load bail. Tighten the collar set screw.
- b. Position the Track 00 flag approximately in the center of its slot and tighten the screw. Move the carriage towards the spindle by rotating the lead screw until the flag is clear of the detector.
- c. Insert the SA120 alignment diskette and load the head. Set the scope as explained in Section 4.11.3 steps c and d.
- d. Step the carriage towards track 00 until the track 00 signal is detected on the interface pin 42.

- e. Loosen the 2 stepper motor mounting screws slightly and slowly rotate the stepper motor case until a read data signal off of track 00 appears. Continue rotation until maximum amplitude is obtained. This is only a rough adjustment.

CAUTION: DO NOT LOOSEN THREE SCREWS COATED WITH GLYPTOL.

- f. Step the carriage to TK 38 and proceed with head radial adjustments. Refer to Section 4.11.3.
- g. Adjust Track 00 stop (Section 4.11.7).
- h. Adjust Track 00 flag (Section 4.11.8).
- i. Adjust index (Section 4.7.3).
- j. Adjust Azimuth (Section 4.11.9).

4.11.3 Head Radial Alignment

Note: Head radial alignment should be checked prior to adjusting index/sector, Track 00 flag or carriage stop.

- a. Load alignment diskette (SA120).
Note: Alignment diskette should be at room conditions for at least twenty minutes before alignment.)
- b. Step the carriage to track 38.
- c. Sync the oscilloscope, external negative, on TP 12 (- CE Index). Set the time base to 20 Msec per division. This will display over one revolution.
- d. Connect one probe to TP 1 and the other to TP 2. Ground the probes on the PCB. Set the inputs to AC, Add and invert one channel. Set the vertical deflection to 100 MV/dev.
- e. The two lobes must be within 70% amplitude of each other. If the lobes do not fall within the specification, continue on with the procedure. Reference Figure 9.
- f. Loosen the two mounting screws which hold the motor clamp to the mounting plate.

CAUTION: DO NOT LOOSEN THREE SCREWS COATED WITH GLYPTOL.

- g. Rotate the stepper motor to radially move the head in or out. If the left lobe is less than 70% of the right, turn the stepper motor counter-clockwise as viewed from the rear. If the right lobe is less than 70% of the left lobe, turn the stepper motor clockwise as viewed from the rear.

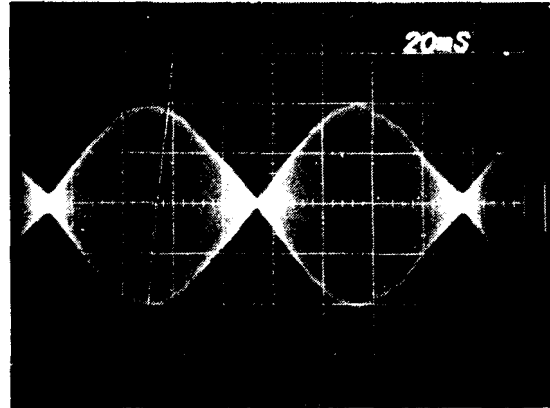

FIGURE 9 HEAD RADIAL ALIGNMENT

- h. When the lobes are of equal amplitude, tighten the motor clamp mounting screws. Reference Figure 9.
- i. Check the adjustment by stepping off track and returning. Check in both directions and readjust as required.
- j. Whenever the Head Radial Alignment has been adjusted, the Track 00 flag adjustment (Section 4.11.8), Track 00 stop (Section 4.11.7) and R/W head azimuth (Section 4.11.9) must be checked.

4.11.3 Read/Write Head Load Button: Removal and Installation

- a. Remove side cover if installed.
- b. To remove the old button, hold the arm out away from head, squeeze the locking tabs together with a pair of needle nose pliers and press forward.
- c. To install load button, press the button into the arm. from the head side, and it will snap in place. Reference Figure 10.

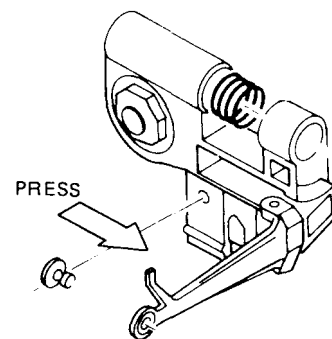

FIGURE 10

d. Adjust according to Section 4.11.4.

Note: The load arm should never be opened over 90° from carriage assembly or while at track 00 to prevent possible damage to the torsion spring.

4.11.4 Read/Write Head Load Button Adjustment

- a. Insert Alignment Diskette (SA120).
- b. Connect oscilloscope to TP 1 and 2, added differentially and sync negative external on TP 12 (- INDEX).
- c. Step carriage to track 75.

d. Observing read signal on oscilloscope, rotate the load button counter-clockwise in small increments (10°) until maximum amplitude is obtained.

4.11.5 Head Penetration Adjustment

Note: This adjustment is not normally done in the field. The only time that this adjustment need be done is when the stepper mounting plate has been loosened or removed.

- a. Place the penetration tool (P/N 50380) on the gauge block and insure that the gauge reads .030 (3 on the small hand) and zero the dial for the large hand. This results in a reading of .030”.

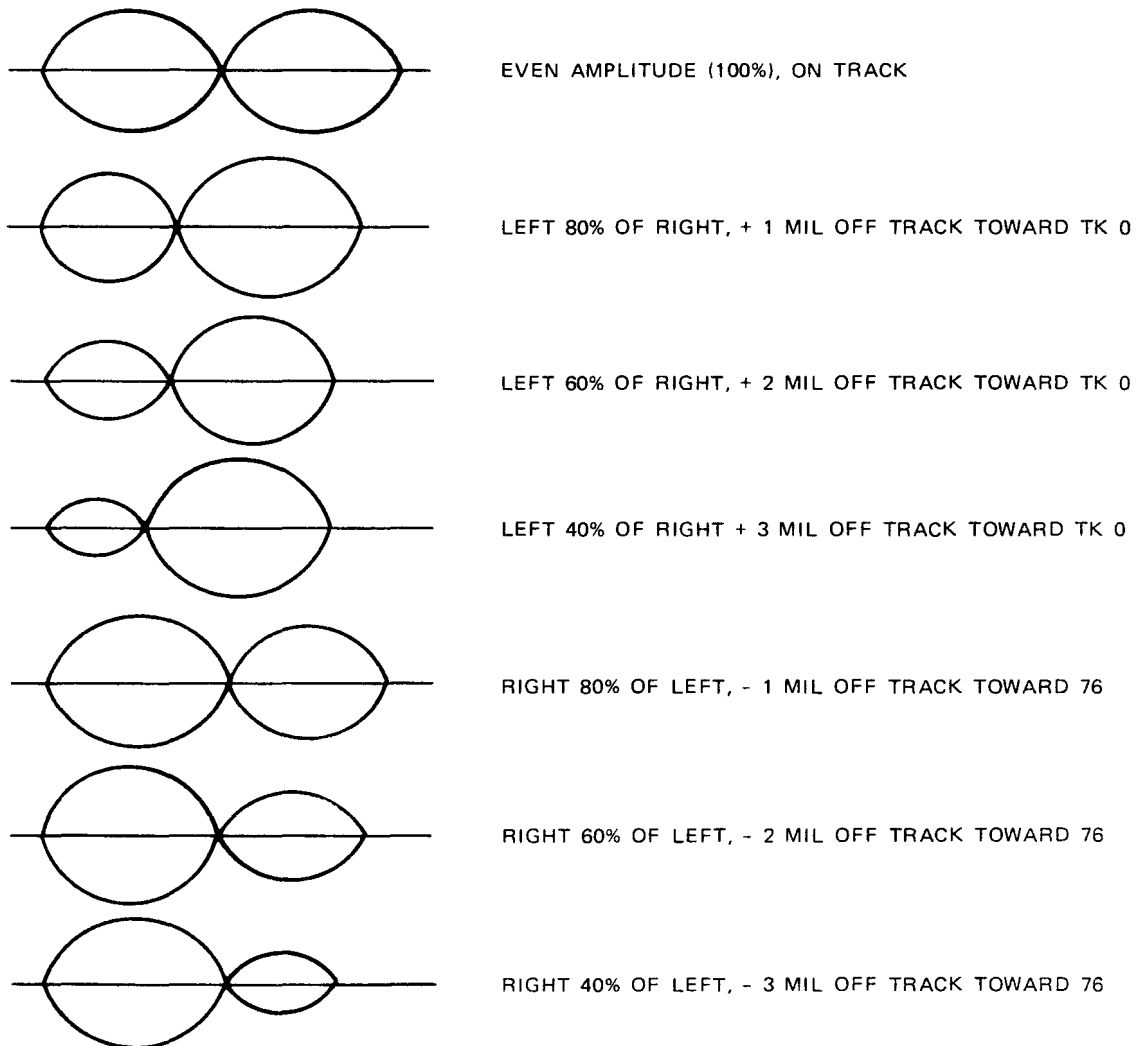

Figure 11 R/W Head Radial Alignment

- b. Swing open the cartridge as per Section 4.3.
- c. Place the penetration tool on the base assembly with the short leg on the platen, the long leg on the carriage guide bar, and the plastic tip in the center of the R/W head.
- d. The head penetration should be $.030'' \pm .003''$ read on the gauge.
- e. If the head does not meet this adjustment, move the stepper plate laterally until the gauge reads $.030''$.
- f. Tighten the screws and recheck the adjustment.
- g. Return carriage guide and adjust as per Section 4.9.2.
- h. Adjust Azimuth (Section 4.11.9).

4.11.6 Track 00 Detector: Removal and Installation

- a. Remove side cover (Section 4.2).
- b. Swing cartridge guide open (Section 4.3).
- c. Manually rotate stepper shaft and move carriage all the way in.
- d. Remove 2 screws holding bracket to base casting and remove bracket and detector.
- e. Remove PCB connector and remove PCB.
- f. Extract cable from P2 connector; Brown, A (R1); Black, C (R3); Red, F (R6); and Orange K (R9).
- g. Remove cable clamps and remove Detector assembly.
- h. To install, reverse the procedure.
- i. Adjust according to Section 4.11.8.

4.11.7 Track 00 Stop Adjustment

- a. Remove side cover (Section 4.2).
- b. Step carriage to track 00. Verify that carriage is at 00 by checking P1 pin 42 is minus (ground).
- c. Check that stop is $.040'' \pm .020''$ between collar and carriage. Turn DC power OFF, and manually rotate lead screw clockwise until carriage stops. Check that stop is $.020'' \pm .010''$ between collar and carriage.

- d. If clearances are not within tolerance, continue on with adjustment procedure.
- e. Turn DC power ON.
- f. Step carriage to track 02.
- g. Loosen Track 00 stop collar.
- h. Grasp end of lead screw, in back of stepper motor, with a pair of pliers and manually turn lead screw clockwise to the track -01 position. (Next detent position on stepper motor.)
- i. Position the stop collar axially along the lead screw so there is $.020'' \pm .010''$ between collar and carriage. Rotate the collar toward inside until the stop on the collar contacts the carriage stop surface. Tighten screw.
- j. Turn DC Power OFF and back ON. Carriage should move to track 00. Verify that there is data at track 00.
- k. Step carriage between track 00 and 76 and check for any binding or interference between the carriage, lead screw, stop and head cable.

4.11.8 Track 00 Flag Adjustment

- a. Remove side cover (Section 4.2).
- b. Check head radial alignment and adjust if necessary before making this adjustment.
- c. Connect oscilloscope probe to TP 26. Set vertical deflection to 1 v/division and sweep to continuous.
- d. Step carriage to track 01. TP 26 should be high (+5 volts).
- e. If TP 26 is not high, loosen screw holding Track 00 flag and move flag towards stepper until TP 26 just goes high.
- f. Step carriage to track 2. TP 26 should go low. Adjust flag towards spindle if not low.
- g. Check adjustment by stepping carriage between tracks 00 and 02, observing that TP 26 is low at track 02 and high at tracks 01 and 00.
- h. Replace side cover.

4.11.9 R/W Head Azimuth Alignment

This adjustment can only be made on SA800/801's at MLC 3 or higher with a new style stepper plate which has 50112-4 stamped on it. This adjustment is only necessary when the stepper or carriage assembly has been replaced or if the stepper plate has been loosened.

- If stepper plate has been loosened or replaced adjust head penetration, Section 4.11.5.
- Align R/W head, 4.11.3.
- Install C.E. alignment diskette SA 120-1. Select the drive and step to track 76.
- Sync the scope external negative on TP 12, set time base to .5 MSec per DIV.
- Connect one probe to TP 1 and the other to TP 2. Invert one channel and ground the probes to TP 5 & 6. Set the inputs to AC, ADD and 50 MV per division.
- Compare the wave form to Figure 13. If not within the range shown the head Azimuth will require adjustment. If required, proceed to next step.
- Slightly loosen the 2 R.H. stepper plate mounting screws only. Reference Figure 12. Do not loosen the L.H. screw as this will effect the head penetration adjustment.

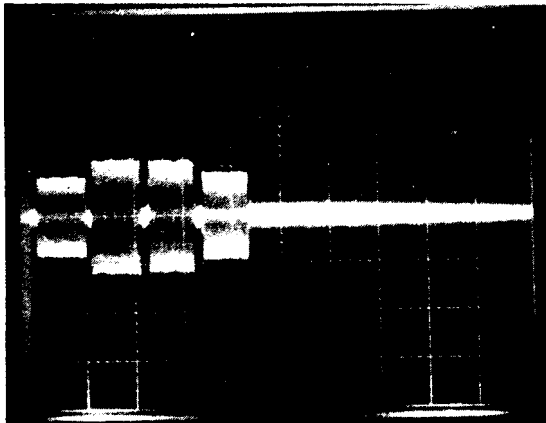

FIGURE 13

- Push the stepper down towards the A.C. drive motor until the 1st sector is larger than the 2nd sector.
- Pry the R.H. side of the stepper plate up with a medium screw driver until the 1st and 4th sectors have equal to or less amplitude than the middle 2 sectors. Reference Figure 13.

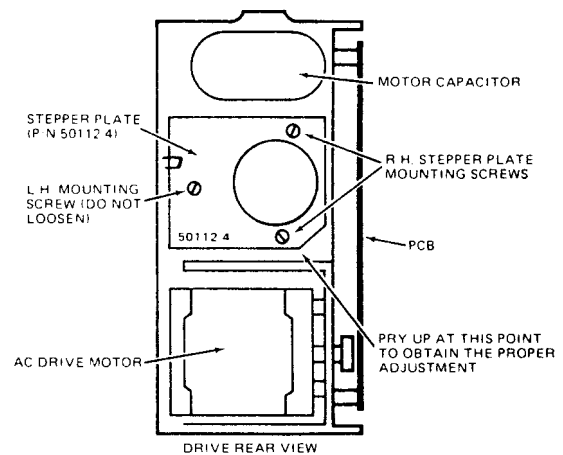

FIGURE 12

- Re-tighten the 2 R.H. screws. If either of the outside 2 sectors increase in amplitude greater than the inside 2 after re-tightening the screws, perform the adjustment again.
- Check and re-adjust the index timing and head radial adjustment if required.

4.11.10 Stepper Plate Removal and Adjustment

- Remove PCB.
 - Remove head and carriage assembly from stepper lead screw, section 4.11.1.
 - Pull the stepper motor out thru the stepper plate until the lead screw is completely clear of the plate.
 - Remove the 3 stepper plate mounting screws.
 - Reinstall the stepper plate.
- NOTE: If the stepper plate is P/N 50112-4, there must be a nylon bushing in the L.H. hole and all 3 screws must have a flat washer and a black spring washer.
- Reinstall head and carriage and stepper motor assemblies.
 - Adjust penetration, Section 4.11.5. If the stepper plate is P/N 50112-4, there will remain a gap between the bottom of the stepper plate and the machined surface on the casting. All other style stepper plates must remain flush with machined surface.
 - Readjust carriage assembly. Section 4.11.2.
 - Check and adjust Azimuth alignment, Section 4.11.10.

4.12 Activity Light Removal and Installation (Standard)

- Remove P6 connector from PCB.
- Remove cable clamp holding the cable and remove cable from clamp.
- Remove the 2 screws holding the push button.
- Remove push button and activity light from the front as an entire assembly.
- Install the light and push button assembly by reversing the removal procedure.
- No special orientation is required when installing P6 onto the PCB. No adjustments are required to the push button assembly.

- Remove front plate (Section 4.10).
- Remove two screws holding assembly to front plate.
- Remove two allen head screws holding assembly to push button.
- Grasp both ends of push button and bow outwards to remove LED.
- Reverse procedure to assemble.
- Adjustment of the door lock should not be necessary. If it has to be, the gap between the armature tab and the latch should be $.015 \pm .010$. This adjustment can be made by loosening the two screws on the armature.

4.13 Door Lock

- Disconnect P6 connector.
- Disconnect red wire near IC 2G.

4.14 Activity Light (with Door Lock Option)

- Follow procedure for door lock (4.13).

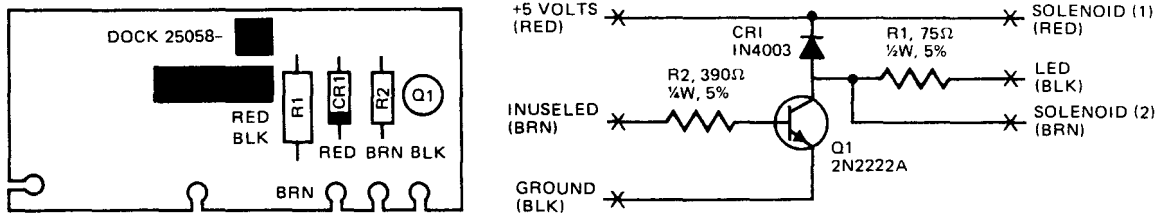
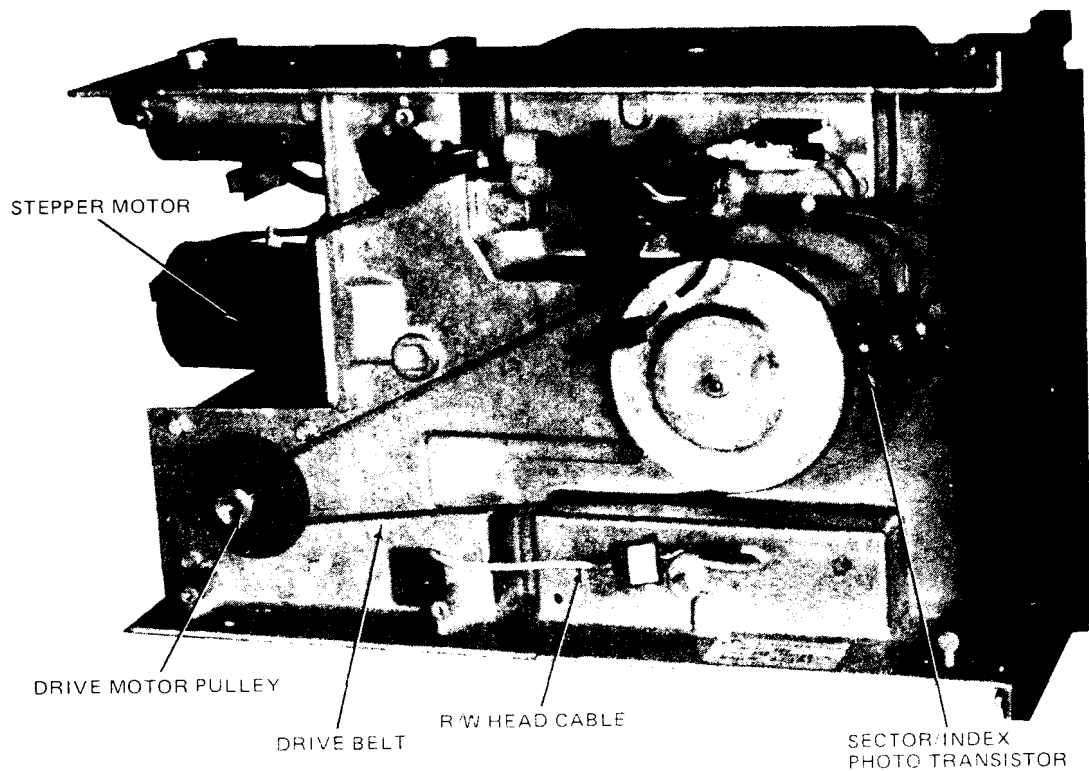
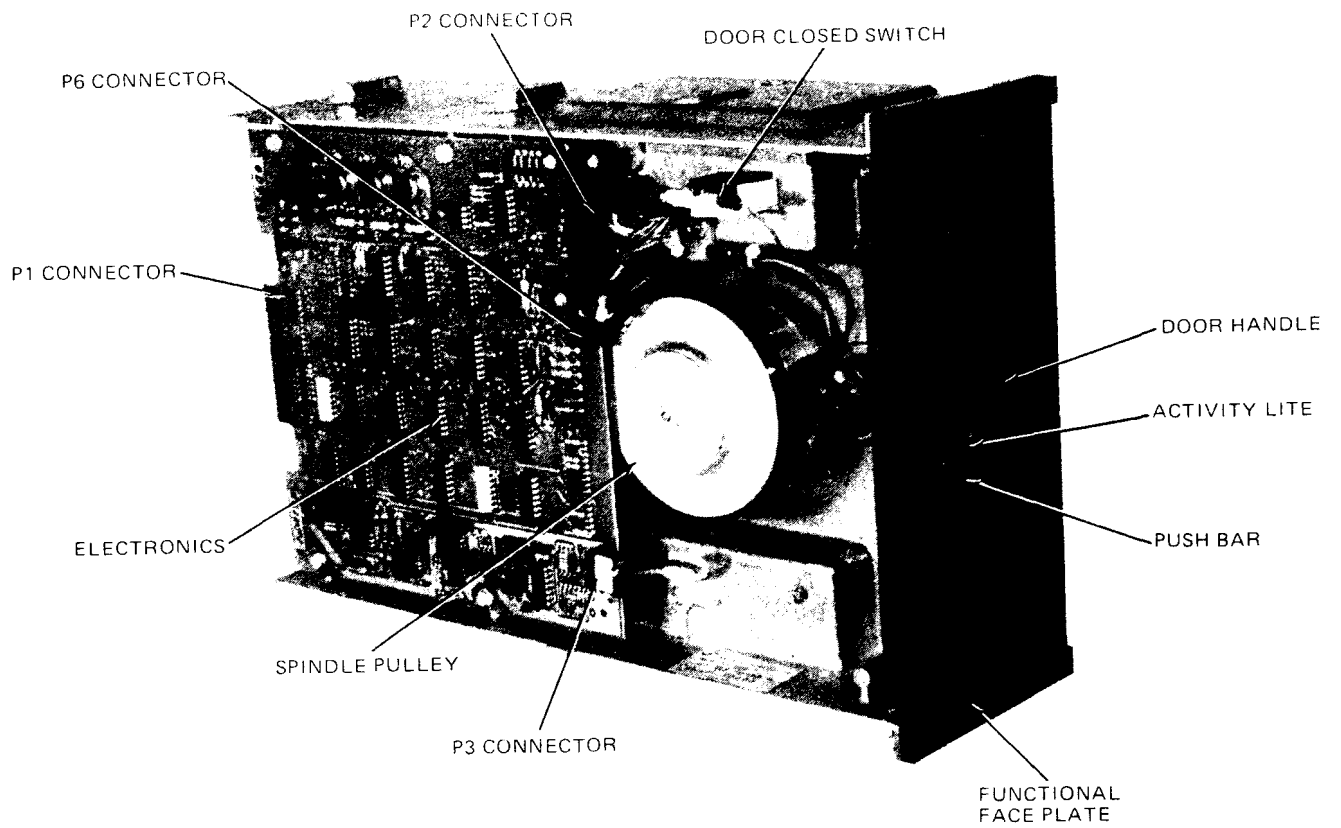
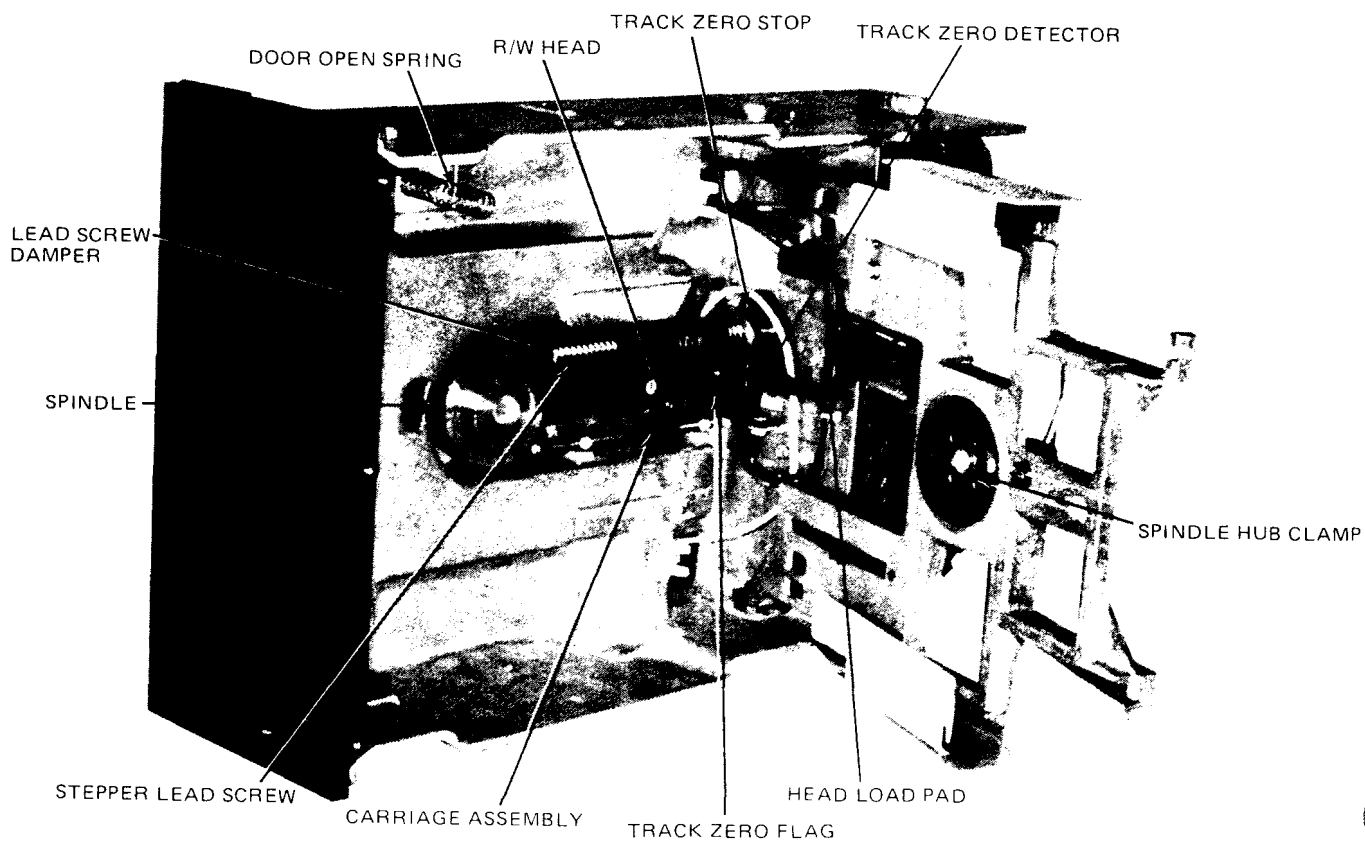
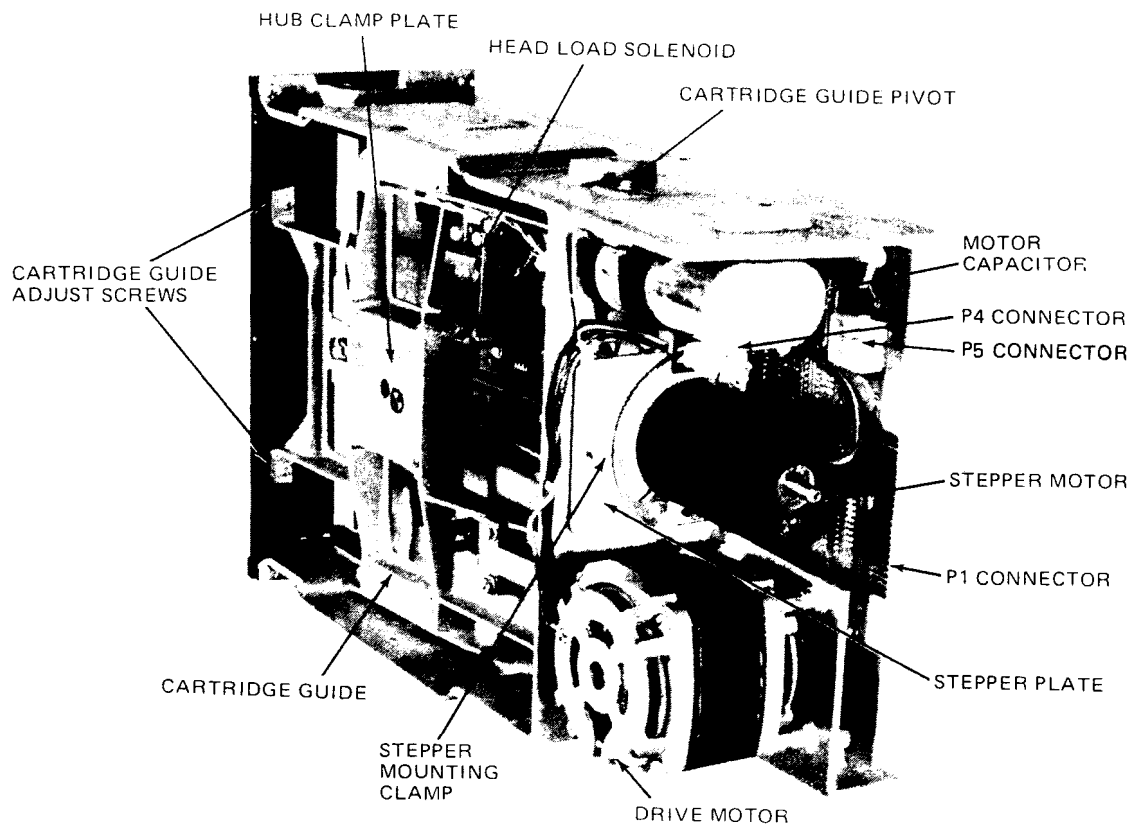
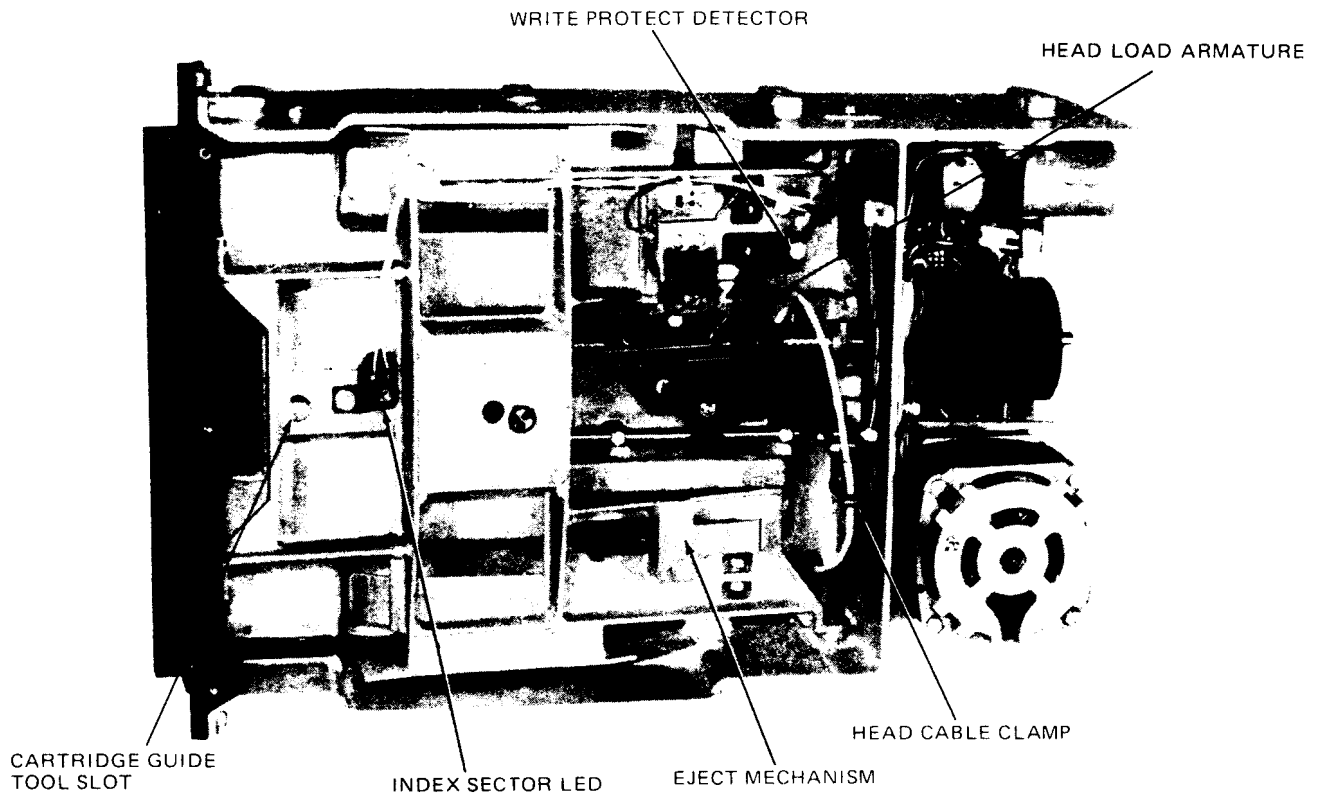

FIGURE 14 DOOR LOCK SCHEMATIC

5 PHYSICAL LOCATIONS







6 SA809 EXERCISER CONNECTION

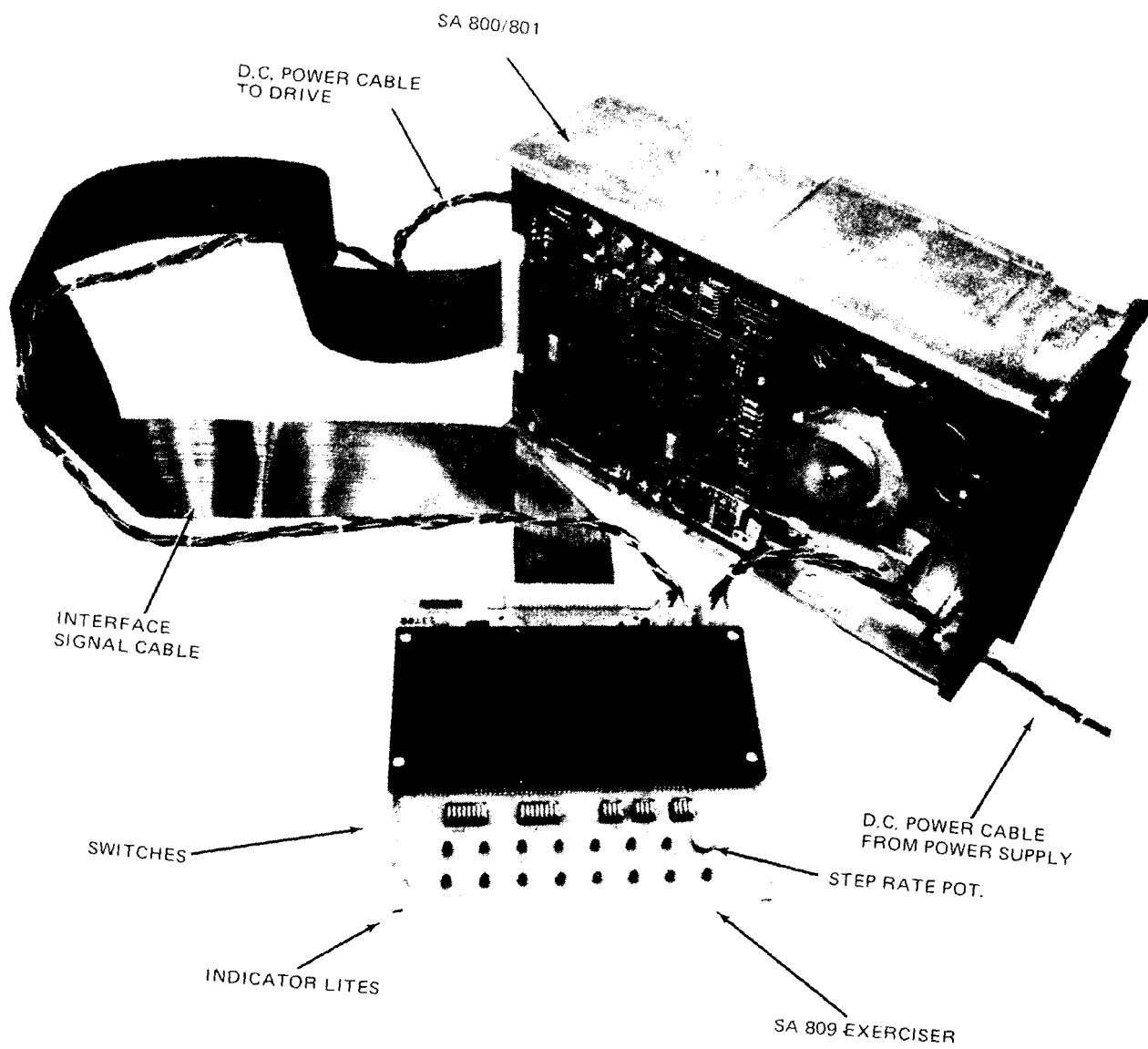

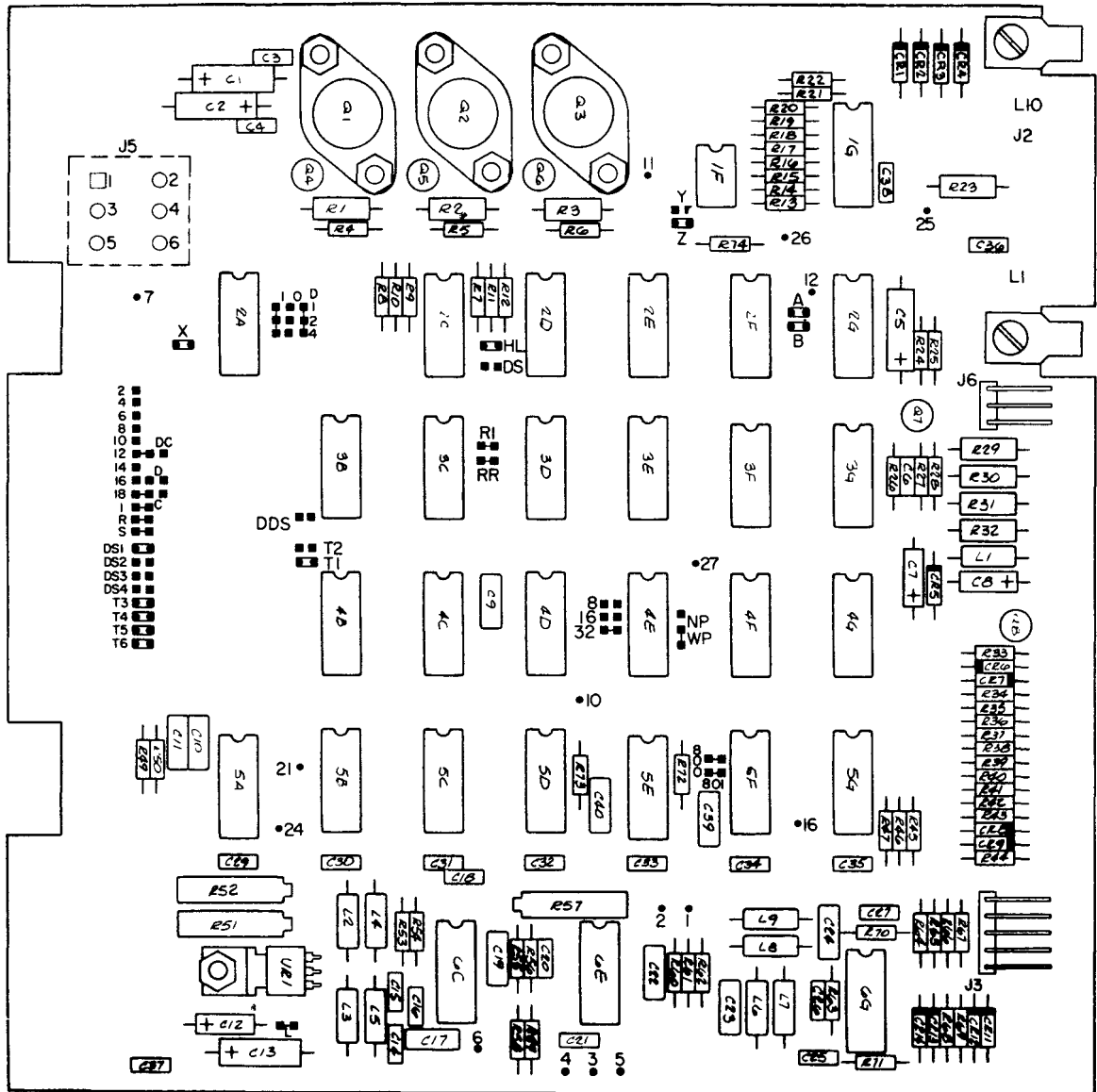

□ Jumper Plug Installed as Shipped

• Test Point

SA800/801 PCB Component Location

LOGIC MANUAL DRIVE SN _____

INDEX

AA001	INDEX
ABO10	PCB TRACE AND TEST POINT LOCATIONS
DA010	READ/WRITE/INDEX/SECTOR
DA020	STEPPER CONTROL
DA030	DETECTORS
DA040	MOTORS SOLENOID SWITCH

TABLE III

CUSTOMER CUT TRACE OPTIONS

DESIGNATOR	DESCRIPTION	SHIPPED FROM FACTORY	
		OPEN	SHORT
T3,T4,T5 & T6	TERMINATIONS FOR MULTIPLEXED INPUTS		<input type="checkbox"/> X
T2	SPARE TERMINATOR FOR RADIAL HEAD LOAD	X	
TI	TERMINATION FOR DRIVE SELECT		<input type="checkbox"/> X
DSI	DRIVE SELECT INPUT - ALTERNATE PINS: DS2, DS3, DS4		<input type="checkbox"/> X
RR	RADIAL READY		X
RI	RADIAL INDEX AND SECTOR		X
R, I, S	READY, INDEX, SECTOR ALTERNATE OUTPUT PROVISION		X
A, B, X	RADIAL HEAD LOAD		<input type="checkbox"/> X
HL	STEPPER POWER FROM HD LD		<input type="checkbox"/> X
DS	STEPPER POWER FROM DRIVE SELECT	X	
WP	INHIBIT WRITE WHEN WRITE PROTECTED		X
NP	ALLOW WRITE WHEN WRITE PROTECTED	X	
8, 16, 32	8, 16 OR 32 SECTORS		
D	ALTERNATE INPUT - IN USE	X	
2,4,6,8,10,12,14,16,18	NINE ALTERNATE I/O PINS	X	
DI, D2, D4, DDS	CUSTOMER INSTALLABLE DECODE DRIVE SELECT OPTION	X	
C	ALTERNATE INPUT - HEAD LOAD	X	
Z	INUSE LED FROM DRIVE SELECT		<input type="checkbox"/> X
Y	INUSE LED FROM HD LD	X	
DC	ALTERNATE OUTPUT - DISK CHANGE	X	

FACTORY CUT TRACE OPTIONS AND HISTORY CHART

L	-5 OR -7 TO -16V	SEE TABLE II
800	INDEX ONLY (800)	SEE TABLE II
801	INDEX AND SECTOR (801)	SEE TABLE II

OPEN TRACE WITH SHORTING PLUG INSTALLED.

TABLE I
OPTIONAL
FEATURES

PCB ASM NO.	OPTIONAL FEATURES			
	-5V	-7 TO -16V	DATA SEP	SECTOR SEP
25102	X			
25103		X		
25104	X		X	
25105		X	X	
25106	X		X	X
25107		X	X	X

WRITE PROTECT CAN BE ORDERED WITH ANY OF THE ABOVE

TABLE II

FACTORY CUT TRACE OPTIONS

PCB ASM NO	TRACE "L"	TRACE "801"	TRACE "800"
25102	SHORTED	OPEN	SHORTED
25103	OPEN	↑	↑
25104	SHORTED	↓	↓
25105	OPEN	OPEN	SHORTED
25106	SHORTED	SHORTED	OPEN
25107	OPEN	SHORTED	OPEN

PART NO
50591-0

LOGIC MANUAL P/N 50590-1

MUST CONFORM TO ENGINEERING SPEC. ES 30000-0		EC HISTORY		SHUGART ASSOCIATES			
MATERIAL	TOLERANCE UNLESS OTHERWISE NOTED	DATE	NO.	TITLE INDEX			
		6-75	0398				
CASE DEPTH	LINEAR ±.XX ±.XXX	1-76	0509	DETAIL DESIGN	6-6-75	RELEASED FOR ASSEMBLY	
HARDNESS	ANGULAR ±			APPRO	6-75	50590	
SURFACE TREATMENT	CORNERS EDGES BROKEN	OUTSIDE INSIDE	MAX MAX	SCALE	DOC CODE	PART NO	REV/EC
				C	OD	50591-0	0509

AA001

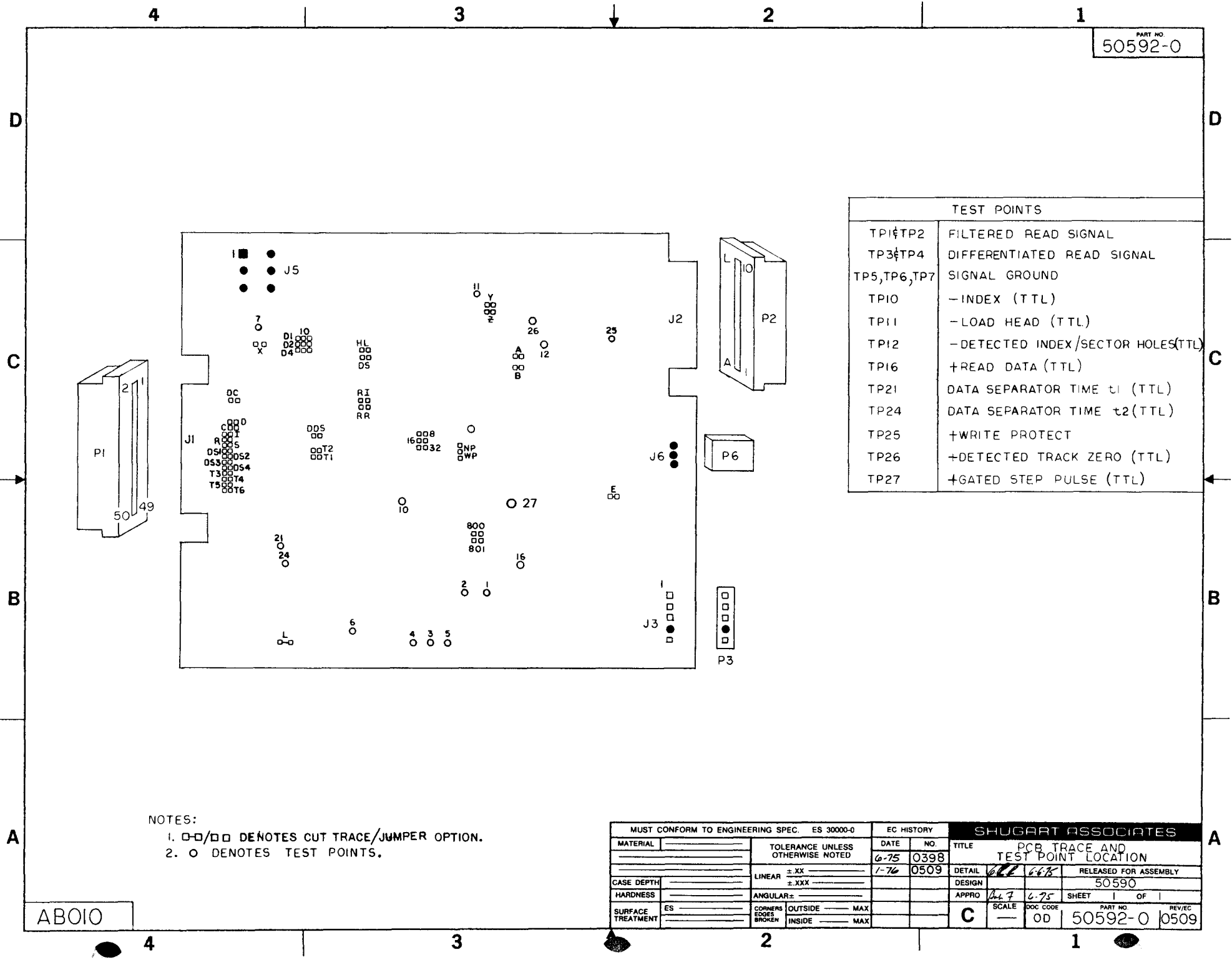

TEST POINTS	
TP1 & TP2	FILTERED READ SIGNAL
TP3 & TP4	DIFFERENTIATED READ SIGNAL
TP5, TP6, TP7	SIGNAL GROUND
TP10	-INDEX (TTL)
TP11	-LOAD HEAD (TTL)
TP12	-DETECTED INDEX/SECTOR HOLES (TTL)
TP16	+READ DATA (TTL)
TP21	DATA SEPARATOR TIME t_1 (TTL)
TP24	DATA SEPARATOR TIME t_2 (TTL)
TP25	+WRITE PROTECT
TP26	+DETECTED TRACK ZERO (TTL)
TP27	+GATED STEP PULSE (TTL)

NOTES:
 1. □-□/□ DENOTES CUT TRACE/JUMPER OPTION.
 2. ○ DENOTES TEST POINTS.

ABOIO

MUST CONFORM TO ENGINEERING SPEC. ES 30000-0		EC HISTORY		SHUGART ASSOCIATES			
MATERIAL	TOLERANCE UNLESS OTHERWISE NOTED	DATE	NO.	TITLE PCB TRACE AND TEST POINT LOCATION			
		6-75	0398	DETAIL	ALL	6/75	RELEASED FOR ASSEMBLY
	LINEAR ±.XX	1-76	0509	DESIGN			50590
CASE DEPTH	±.XXX			APPRO	ALF	6-75	SHEET 1 OF 1
HARDNESS	ANGULAR ±			SCALE			PART NO 50592-0
SURFACE TREATMENT	ES	CORNERS BROKEN	OUTSIDE MAX	C	DOC CODE	OD	REV/EC 0509
			INSIDE MAX				

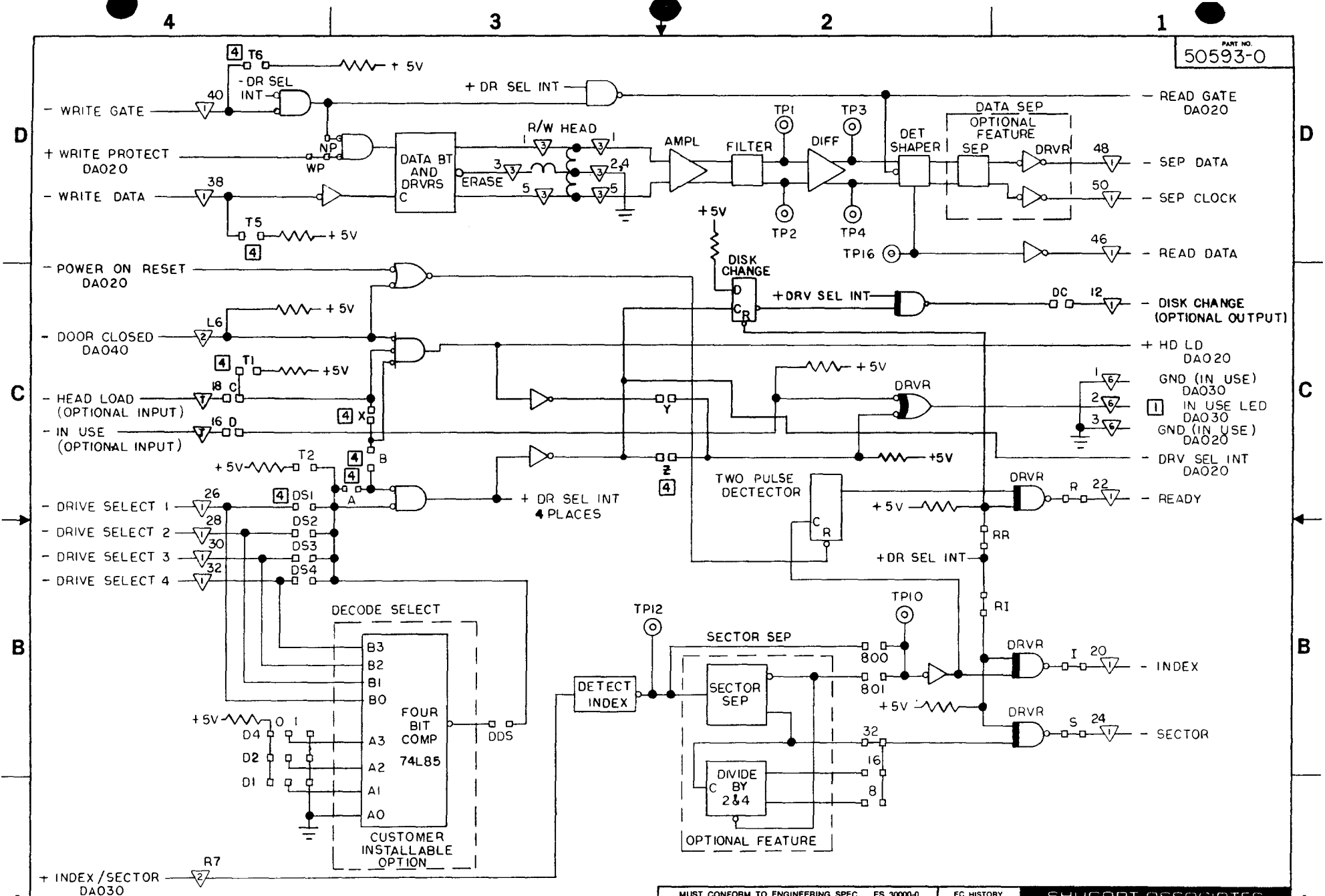

- NOTES:
- 1 GND WHEN INACTIVE AND +1.5VDC WHEN ACTIVE
 - 2. CONNECTOR SYMBOL REFERENCE $\nabla=J1, \nabla=J2, \nabla=J3, \nabla=J6$
 - 3. ALL ODD NUMBERED PINS ON J1 CONNECTOR ARE GROUND.
 - 4 SHORTING PLUG INSTALLED.

DAO10

MUST CONFORM TO ENGINEERING SPEC. ES 30000-0		EC HISTORY		SHUGART ASSOCIATES	
MATERIAL	TOLERANCE UNLESS OTHERWISE NOTED	DATE	NO.	TITLE	
		6-75	0398	READ/WRITE /INDEX/SECTOR	
		1-76	0509	DETAIL	RELEASED FOR ASSEMBLY
CASE DEPTH	LINEAR ±.XX			DESIGN	50590
HARDNESS	ANGULAR ±.XXX			APPRO	
				SCALE	
SURFACE TREATMENT	CORNERS BROKEN	OUTSIDE	MAX	DOC CODE	PART NO
	INSIDE	MAX		OD	50593-0
					REV EC
					0509

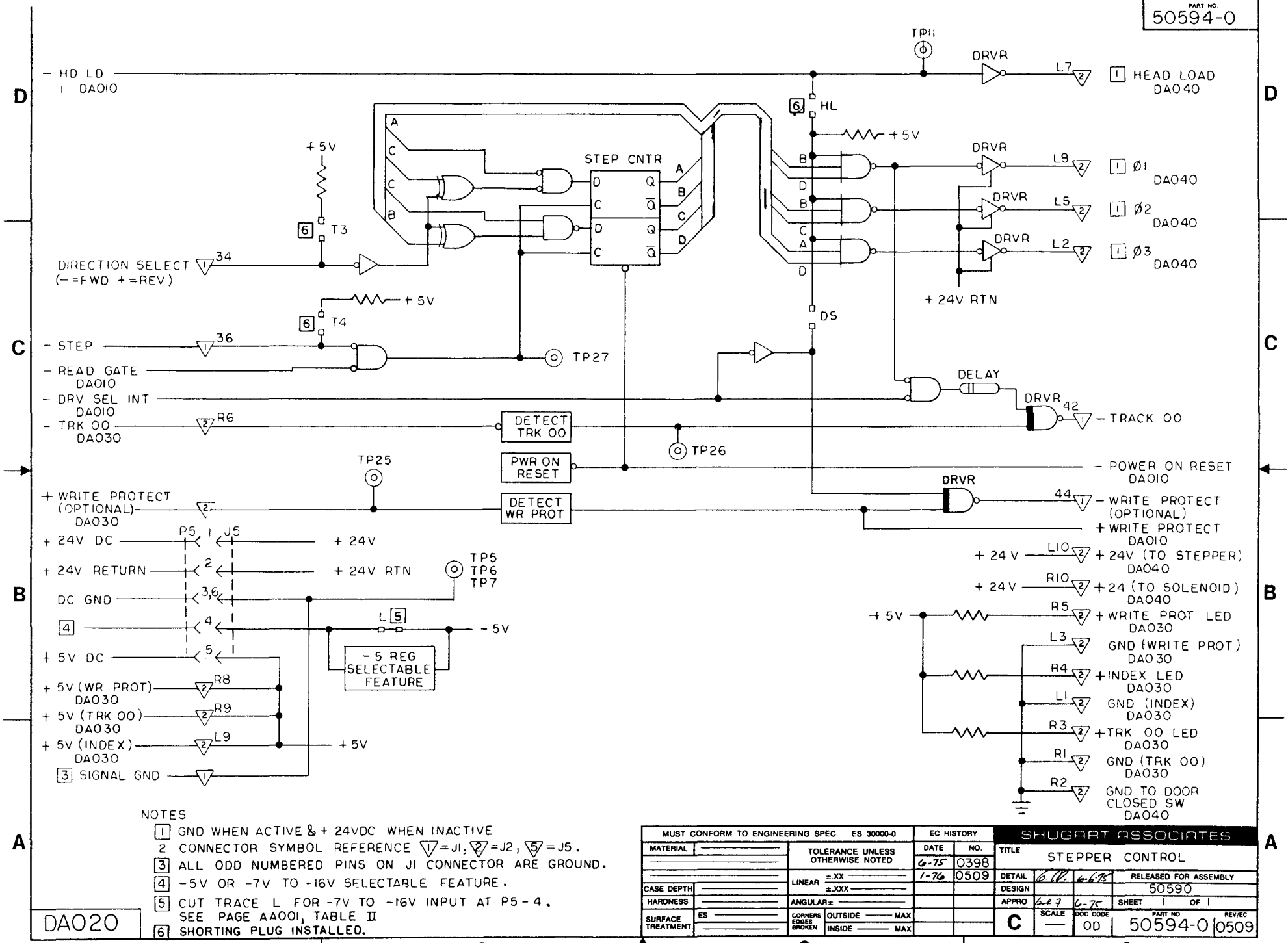

NOTES

- 1 GND WHEN ACTIVE & + 24VDC WHEN INACTIVE
- 2 CONNECTOR SYMBOL REFERENCE ▽=J1, ▽=J2, ▽=J5.
- 3 ALL ODD NUMBERED PINS ON J1 CONNECTOR ARE GROUND.
- 4 -5V OR -7V TO -16V SELECTABLE FEATURE.
- 5 CUT TRACE L FOR -7V TO -16V INPUT AT P5-4. SEE PAGE AAOOI, TABLE II
- 6 SHORTING PLUG INSTALLED.

DAO20

MUST CONFORM TO ENGINEERING SPEC. ES 30000-0		EC HISTORY		SHUGART ASSOCIATES	
MATERIAL	TOLERANCE UNLESS OTHERWISE NOTED	DATE	NO.	TITLE	
		6-75	0398	STEPPER CONTROL	
CASE DEPTH	LINEAR ±.XX	1-76	0509	DETAIL	RELEASED FOR ASSEMBLY
HARDNESS	ANGULAR ±.XXX			DESIGN	50590
SURFACE TREATMENT	ES			APPRO	SHEET 1 OF 1
	CORNERS EDGES BROKEN			SCALE	DOC CODE
	OUTSIDE MAX				PART NO
	INSIDE MAX				REV/EC
				C	00
					50594-0
					0509

4

3

2

1

PART NO.
50595-0

D

D

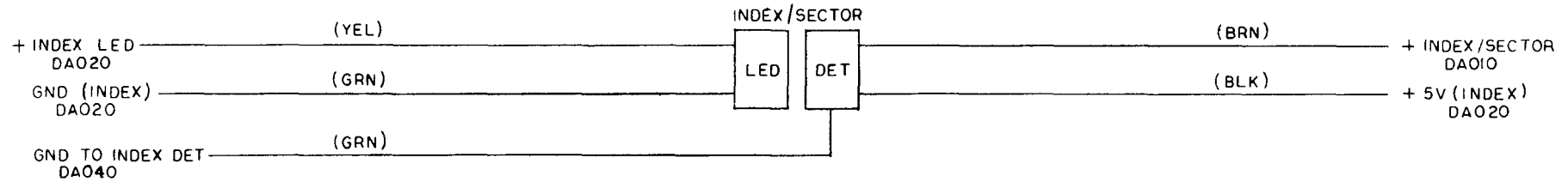

C

C

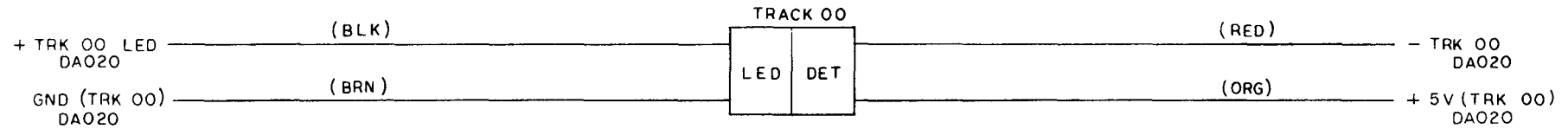

B

B

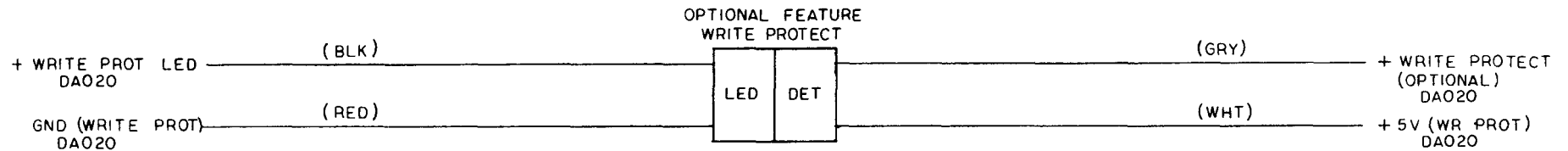

A

A

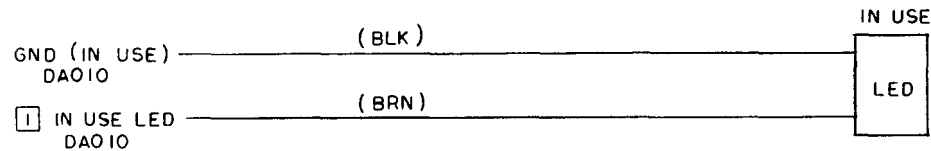

NOTES:

 GND WHEN INACTIVE AND +1.5VDC WHEN ACTIVE

DAO30

MUST CONFORM TO ENGINEERING SPEC. ES 30000-0			EC HISTORY		SHUGART ASSOCIATES			
MATERIAL		TOLERANCE UNLESS OTHERWISE NOTED	DATE	NO.	TITLE			
			6-75	0398	DETECTORS			
		LINEAR ±.XX			DETAIL	6-75	6-75	RELEASED FOR ASSEMBLY
CASE DEPTH		±.XXX			DESIGN			50590
HARDNESS		ANGULAR ±			APPRO	6-75	6-75	SHEET 1 OF 1
SURFACE TREATMENT	ES	CORNERS OUTSIDE MAX			SCALE	OD	DOC CODE	PART NO. REV/EC
		EDGES INSIDE MAX			C			50595-0 0398

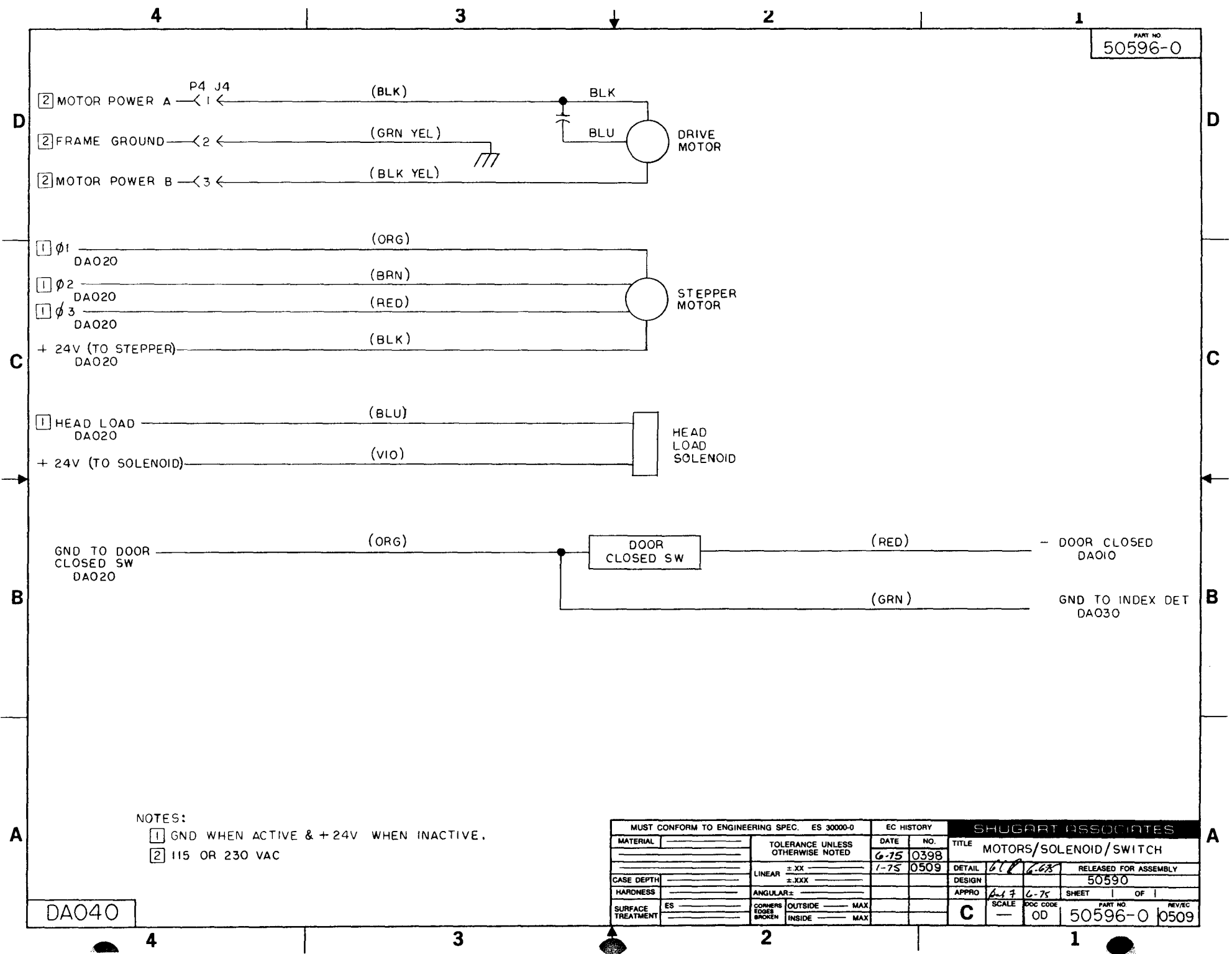

NOTES:
 1 GND WHEN ACTIVE & +24V WHEN INACTIVE.
 2 115 OR 230 VAC

DA040

MUST CONFORM TO ENGINEERING SPEC. ES 30000-0			EC HISTORY		SHUGART ASSOCIATES			
MATERIAL	TOLERANCE UNLESS OTHERWISE NOTED	DATE	NO.	TITLE				
		6-75	0398	MOTORS/SOLENOID/SWITCH				
CASE DEPTH	LINEAR	1-75	0509	DETAIL	6-75	6-68	RELEASED FOR ASSEMBLY	
HARDNESS	ANGULAR			DESIGN			50590	
SURFACE TREATMENT	ES	OUTSIDE	MAX	APPRO	6-75		SHEET	OF 1
	CORNERS EDGES BROKEN	INSIDE	MAX	SCALE	—	OD	PART NO 50596-0 REV/EC 0509	

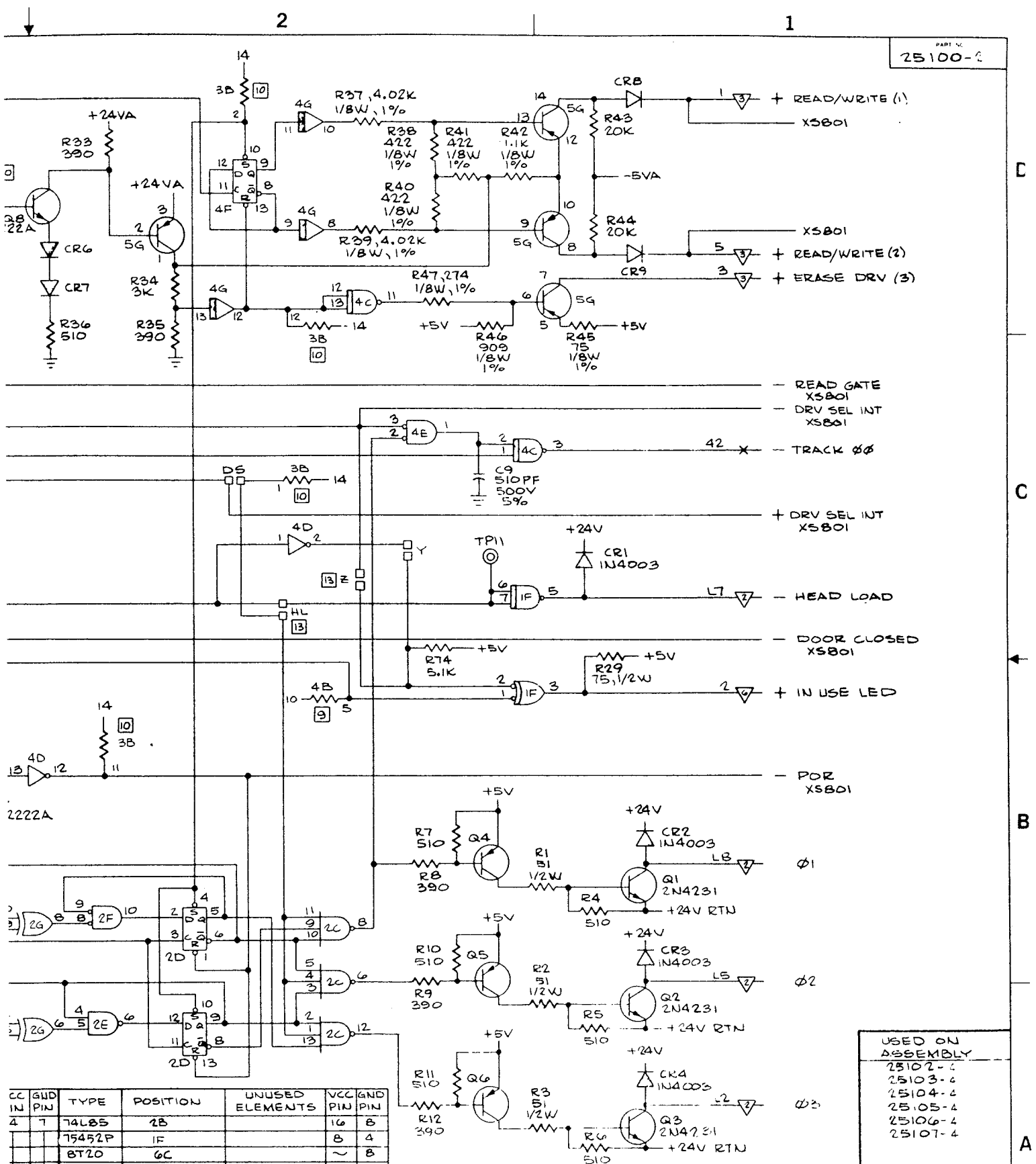

CC IN	GRID PIN	TYPE	POSITION	UNUSED ELEMENTS	VCC PIN	GND PIN
4	7	74LS5	2B		16	8
		75452P	1F		8	4
		8T20	6C		~	8
		9602	5A, 5E, 3G		16	8
		LM339	1G	1G3	3	12
		NES92A	6E		~	~
		2QT2222	6G		~	~
		2QT2905	5G		~	~
3	13	742B	2F		14	7
4	7	7427	2A	2A1, 2	14	7

MUST CONFORM TO ENGINEERING SPEC. ES 30000-0

MATERIAL		TOLERANCE UNLESS OTHERWISE NOTED		FC HISTORY		SHUGART ASSOCIATES	
DATE	NO.	DATE	NO.	DATE	NO.	TITLE	SCHEMATIC DIAGRAM
DESIGN		DATE	NO.	DATE	NO.	DISKETTE, 800 SERIES	
APPRO		SCALE		SCALE		RELEASED FOR ASSEMBLY	
SURFACE TREATMENT	ES	CORNERS EDGES BROKEN	OUTSIDE MAX	INSIDE MAX		T25100	
						SHEET 1 OF 2	
						PART NO. 25100-2	REV TC 0102

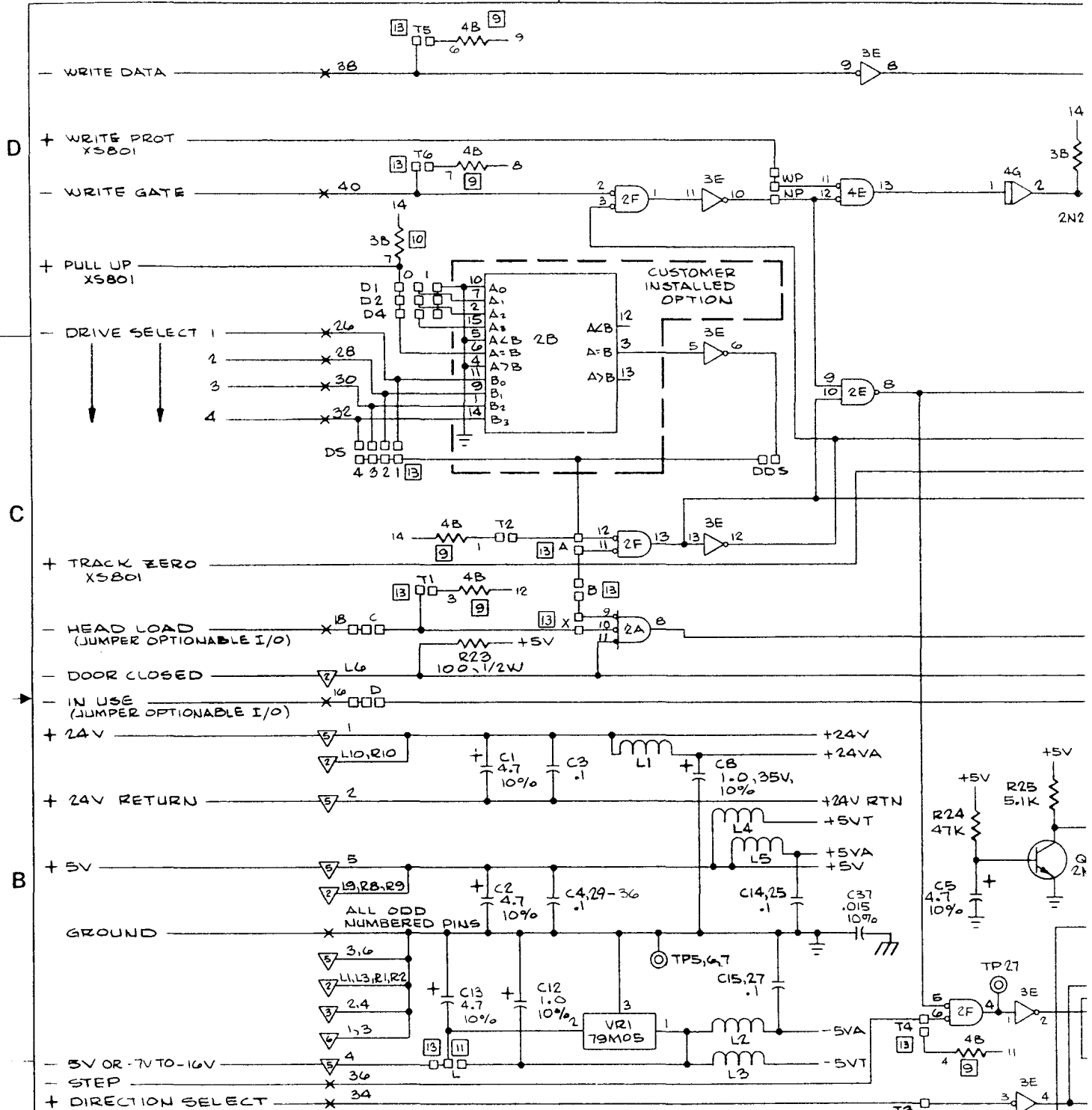

NOTES, UNLESS OTHERWISE SPECIFIED:

1. ALL RESISTORS ARE IN OHMS, 1/4W, 5%.
2. ALL CAPACITORS ARE IN MICROFARADS, 50V, +80-20%.
3. ALL INDUCTORS ARE 100MH, 10%.
4. ALL DIODES ARE IN4148.
5. ALL TRANSISTORS ARE 2N2907A.
6. D-D INDICATES CUT-TRACE OPTION.
7. D-D INDICATES JUMPER OPTION.
8. CONNECTOR SYMBOL REFERENCES; (X)=J1, (∇)=J2, (∩)=J3, (∪)=J5, (∩)=J6.
9. I.C. LOCATION 4B IS A RESISTOR PACK, 150Ω, 1/2W, 5%.
10. I.C. LOCATION 3B IS A RESISTOR PACK, 2K, 1/4W, 5%.
11. ADD JUMPER L FOR -7V TO 16V ON ASSEMBLIES; 25103, 25105, 25107.
12. PINS 8 AND 9 OF IC ARE GROUND.
13. SHORTING PLUG INSTALLED.
14. REMOVE JUMPER FROM 800 AND INSTALL IN 801.

REFERENCE DESIGNATION LAST USED	NOT USED
C40	C28 (RESERVED)
CR14	CR10
L9	
R8	
R74	R4B
TP27	1P8, 9, 10, 15, 17-20, 22, 23.
VR1	

TYPE	POSITION	UNUSED ELEMENTS
7400	5C, 2E, 5F	2E1, 4, 5F2, 4
7402	4E	4E3
7404	3E	
7405	4D	4D2, 3
7407	4G	
7410	5B, 2C	5B1
7438	3C, 4C	
7474	2D, 3D, 5D, 4F	
7476	3F	
7486	2G	2G4

X5B00

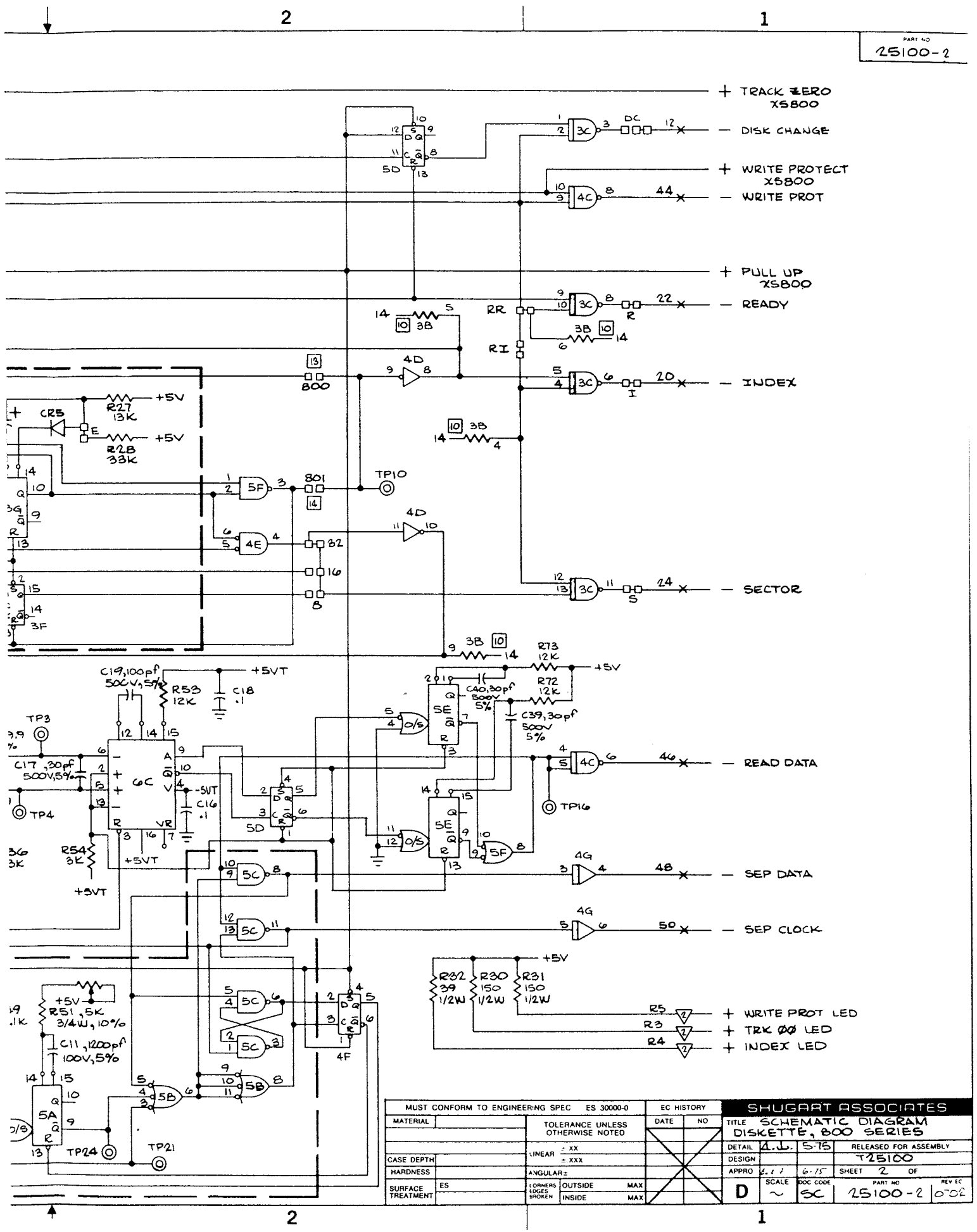

MUST CONFORM TO ENGINEERING SPEC ES 30000-0		EC HISTORY		SHUGART ASSOCIATES			
MATERIAL	TOLERANCE UNLESS OTHERWISE NOTED	DATE	NO	TITLE SCHEMATIC DIAGRAM DISKETTE, 800 SERIES		RELEASED FOR ASSEMBLY	
CASE DEPTH	LINEAR = .XX = .XXX			DESIGN	A.J. S-75	T25100	
HARDNESS	ANGULAR =			APPRO	6.1 / 6.15	SHEET 2 OF	
SURFACE TREATMENT	CORNERS EDGES BROKEN	OUTSIDE	MAX	SCALE	DOC CODE	PART NO	REV EC
		INSIDE	MAX	~	SC	25100-2	002

D

C

B

A

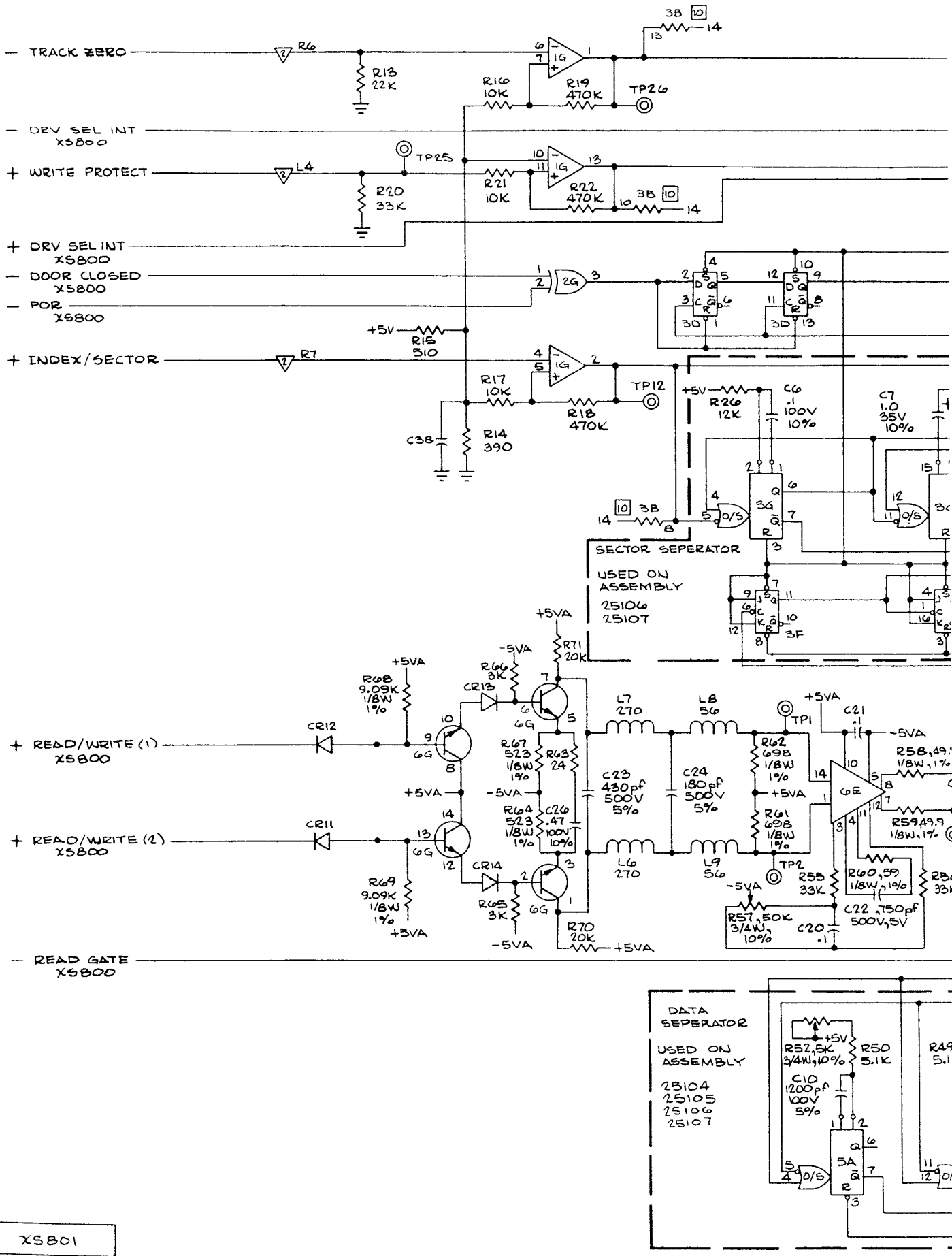

XS801



435 Oakmead Parkway, Sunnyvale, California 94086
Phone: (408) 733-0100 TWX: 910 339 9355 SHUGART SUVL